



MANUAL NO. 29
SOFTWARE VERSION
1.8 and HIGHER

**Model ETR-3200
AUTOMATIC TUNING 1/32 DIN
SMARTER LOGIC[®] Controller**



INSTRUCTION MANUAL

INSTRUCTION MANUAL FOR ETR-3200



CONTENTS

Section 1: INTRODUCTION

This manual contains information for the installation and operation of the Ogden Model ETR-3200 auto-tuning micro-processor based controller.

Ease of use is an essential feature on this versatile controller. Three touch keys are used to select sensor type, control mode, control parameters, alarm mode, degrees C/F, auto-manual mode, and to lock the parameters from the prevention of unauthorized tampering. A large 4-digit display shows process values at a glance. Precise 14 slope sensor linearization, self-diagnostic capability, cold junction compensation and 3-mode PID calculations are automatically executed by the single chip microprocessor. The wide selection of parameters, values, sensor types, set points, control modes, alarm modes, degrees C/F and security codes

are held in a non-volatile memory. Batteries are not necessary.

The auto-tuning function determines the correct proportional band, rate and reset values to provide accurate control with minimal overshoot and temperature oscillation. This is accomplished without the need for expensive and time consuming procedures for set-up of control parameters. In case of a power failure or temporary shutdown, the instrument retains the correct parameters. This instrument also has manual override capabilities that allow the operator to bypass the auto-tuning parameters. Required fine tuning adjustments can then be made.

WARNING!

Failure of devices, such as the thermocouple-RTD sensor, heater output relay or temperature control can result in severe damage to a product while in process, melting of the heater or a damaging fire. An over-temperature protection device must be installed in your process that will remove all power from the heating circuit if the above failure occurs. We recommend that this device be classified as a safety control and carry FM, U.L. and CSA Listing or Certification. Failure to install high-limit temperature control protection where a potential hazard exists, could result in damage to equipment and property, and fatal injury to personnel.



64 West Seegers Road
Arlington Heights, IL 60005
(847) 593-8050 • Fax: (847) 593-8062
www.ogdenmfg.com • sales@ogdenmfg.com

© Ogden Manufacturing Co. 1999
OGDEN, SMARTER LOGIC, ETR and
ETR-3200 are Registered Trademarks of
Ogden Manufacturing Co.
MARCA REGISTRADA

Section 2: CATALOG NUMBERING SYSTEM

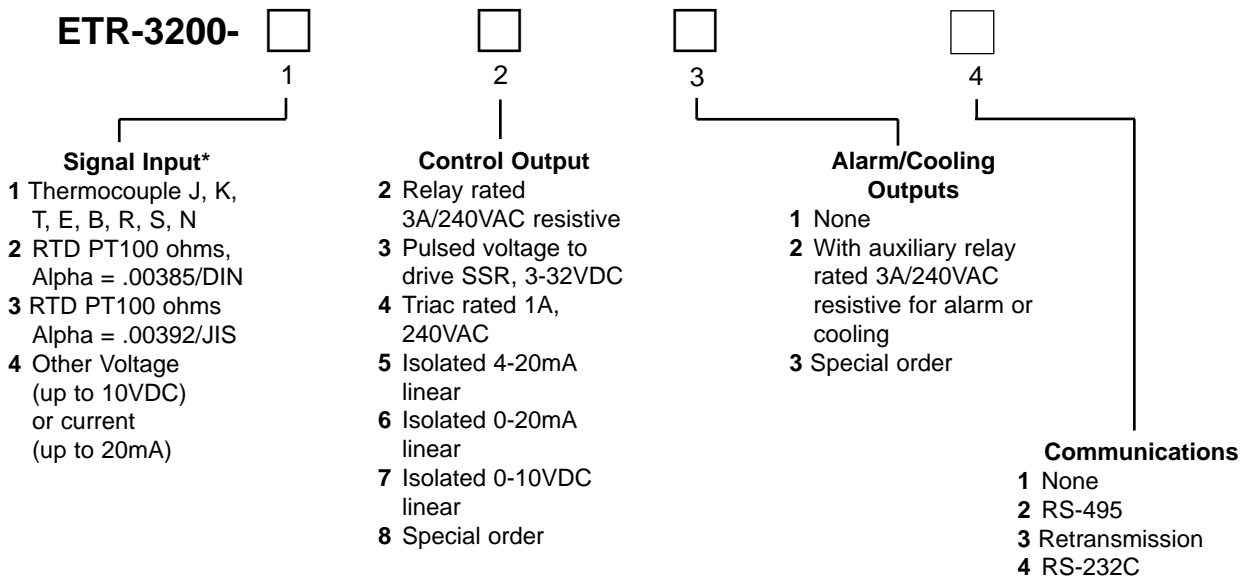

Example:

ETR-3200-1221

- Thermocouple type J, K, T, E, B, R, S, N
- Relay Output
- With Alarm/Cooling Option

NOTE: True universal input can be re-programmed in the field.

NOTE: If a low voltage power source is used, place the number "3" before the Signal Input for 20-32VAC/VDC operation.

Maximum Temperature Ranges or SPAN:

Sensor	Input Type	Max. Range F°	Sensor Accuracy F°	Max. Range C°	Sensor Accuracy C°
J	Iron/Constantan	-58 to 1832°F	±3.6°F	-50 to 1000°C	±2°C
K	Chromel/Alumel	-58 to 2500°F	±3.6°F	-50 to 1370°C	±2°C
T	Copper/Constantan	-454 to 752°F	±3.6°F	-270 to 400°C	±2°C
E	Chromel/Constantan	-58 to 1382°F	±3.6°F	-50 to 750°C	±2°C
B	Pt-30%RH/Pt-6%RH	32 to 3272°F	±5.4°F	0 to 1800°C	±3°C
R	Pt-13%RH/Pt	32 to 3182°F	±3.6°F	0 to 1750°C	±2°C
S	Pt-10%RH/Pt	32 to 3182°F	±3.6°F	0 to 1750°C	±2°C
N	Nicrosil/Nisil	-58 to 2372°F	±3.6°F	-50 to 1300°C	±2°C
RTD	PT 100 ohms (DIN)	-328 to 752°F	±0.72°F	-200 to 400°C	±0.4°C
RTD	PT 100 ohms (JIS)	-328 to 752°F	±0.72°F	-200 to 400°C	±0.4°C
Linear	4 - 20 mA	-1999 to 9999	±0.05%	-1999 to 9999	±0.05%
Linear	0 - 20 mA	-1999 to 9999	±0.05%	-1999 to 9999	±0.05%
Linear	0 - 1 VDC	-1999 to 9999	±0.05%	-1999 to 9999	±0.05%
Linear	0 - 5 VDC	-1999 to 9999	±0.05%	-1999 to 9999	±0.05%
Linear	1 - 5 VDC	-1999 to 9999	±0.05%	-1999 to 9999	±0.05%
Linear	0 - 10 VDC	-1999 to 9999	±0.05%	-1999 to 9999	±0.05%

Chromel® and Alumel® are Registered Trademarks of Hoskins Manufacturing Company.

Section 3: SPECIFICATIONS

Line Voltage:	90-264VAC, 50-60Hz, 20-32VAC/DC optional	Dimensions:	Front Panel H - $1\frac{5}{16}$ " (24mm) W - $1\frac{7}{8}$ "(48mm) D - $4\frac{5}{16}$ " (110mm) Depth Behind Panel: $3\frac{7}{8}$ " (99mm)
Consumption:	Less than 5VA.	Panel Cutout:	$\frac{7}{8}$ "x $1\frac{25}{32}$ " (22 x 45mm)
Input:	Thermocouple Type: J, K, T, E, B, R, S, N RTD 2 or 3 wire PT-100 DIN @ = .00385 or JIS @ = .00392 0 - 1V, 0 - 5V, 1 - 5V, 0 - 10V, 0 - 20mA, 4 - 20mA	Proportional Band:	0 - 360°F (0 - 200°C)
Linear Voltage Input Impedance:	100k ohms	Integral (Reset):	0 - 3600 seconds
Cold Junction Compensation:	.1°C/C ambient typical	Derivative (Rate):	0 - 1000 seconds
Sensor Break Protection:	Operator selectable	Ramp Rate:	0- 99.99°F (0 - 55.55°C) /minute
External Resistance:	100 ohms max.	Dwell:	0 - 9999 minutes
Sample Rate:	5 samples per second	On-Off:	Adjustable hysteresis (0.1 - 19.9°F, (0 - 11.0°C)
Accuracy:	±.1%, ±least significant digit	Proportional Cycle Time:	0 - 99 seconds
Normal Mode Rejection:	60db	°F/°C:	External keypad selectable
Common Mode Rejection:	120db	Linearization:	Software driven
Operating Ambient for Rated Accuracy:	14 - 122°F (-10 - 50°C)	Outputs:	Heating or cooling/alarm
Storage Temperature:	-4 - 160°F (-20 - 70°C)	Output Modules:	
Humidity:	5 - 90% RH (non-condensing)	-Linear Current:	4-20mA isolated, max. load 500 ohms
Insulation:	20M ohms min. (500VDC)	-Linear Voltage:	0 - 10V isolated, minimum impedance 500K ohms
Breakdown:	2000V (AC), 50/60Hz, 1 minute	-Pulsed Logic Voltage:	24VDC, unisolated Max. current 20mA
Shock:	200m/s ² (20g)	-Triac:	Rated 1A, 240V max.
Weight:	4 oz. (110 grams)	-Relay:	3A/240V, resistive load for heating, 3A/240V, resistive load for alarm
EMC Emission:	EN50081-1, EN61326 (EN55011 class B, EN61000- 3-2, EN61000-3-3)	Control Actions:	Heating (relay closed on temperature rise) or cooling (relay open on temperature rise) front panel selectable
EMC Immunity:	EN50082-2, EN61326 (EN6100-4-2, EN61000-4-3, EN61000-4-4, EN61000-4-5, EN61000-4-6, EN6100-4-11)		

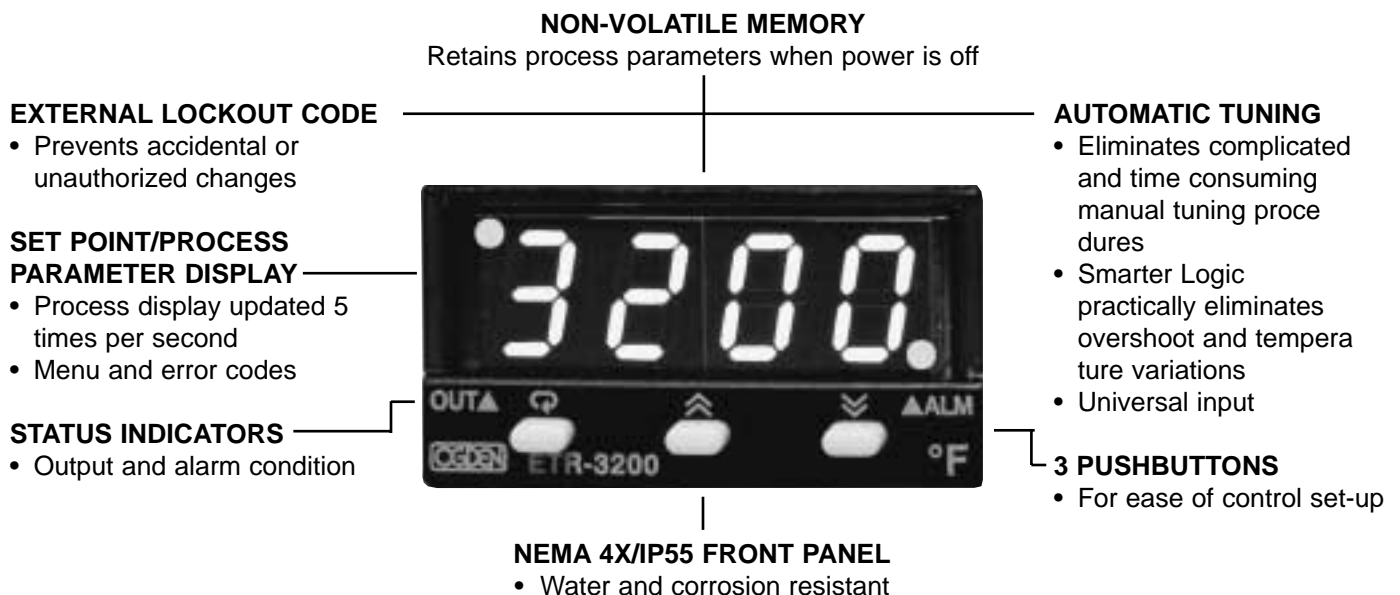

Section 4: INSTALLATION

WARNING!



RISK OF ELECTRIC SHOCK - Dangerous and potentially fatal voltages are present when working on this equipment. Before installation or beginning any troubleshooting procedures, the electric power to this equipment must be disconnected and locked out as described by OSHA Standards. Units suspected of being faulty must be removed and returned to Ogden for inspection and/or repair. They contain no user serviceable components.

WARNING!



To help minimize the possibility of fire or shock hazards, do not expose this instrument to rain or excessive moisture. This control is not to be used in hazardous locations as defined in Articles 500 and 505 of the National Electric Code.

WARNING!



Do not use this instrument in areas subject to hazardous conditions such as excessive shock, vibration, dirt, moisture, corrosive gases or oil. The ambient temperature of the areas should not exceed the maximum rating specified in Section 3, on previous page.

Unpacking:

Upon receipt of the shipment inspect the unit for shipping damage. If any damage due to transit is noticed, report and file a claim with the carrier. Write down the model number and serial number for future reference when corresponding with our service center. The serial number is located on the housing of the control.

Mounting:

Make panel cutout to dimensions shown below. Insert the controller into the panel cutout. The maximum panel thickness is 1/8" (3.2mm).

Wiring Precautions:

- Before wiring, verify the label for correct model number and options. Switch off the power when checking.
- Care must be taken to ensure that maximum voltage ratings specified in Section 3 on previous page are not exceeded.
- It is recommended that power to these instruments be protected by fuses and circuit breakers rated at the minimum value possible.
- All units should be installed inside a suitably grounded metal enclosure to prevent live parts being accessible to human hands and metal tools.
- All wiring must conform to appropriate standards of good practice, national and local codes and regulations. Wiring must be suitable for the maximum voltage, current, and temperature ratings expected in the system.
- Take care not to over-tighten the terminal screws.
- Unused control terminals should not be used as jumper points as they may be internally connected, causing damage to the unit.
- Verify that the ratings of the output devices and the inputs as specified on page 3 are not exceeded.
- Electric power in industrial environments contains a certain amount of noise in the form of transient voltages and spikes. This electrical noise can enter and adversely affect the operation of microprocessor-based controls. For this reason we strongly recommend the use of shielded thermocouple extension wire which connects from the sensor to the controller. This wire is a twisted-pair construction with foil wrap and drain wire. The drain wire is to be attached to earth ground at the sensor end only. We carry both type J and type K in our stock.

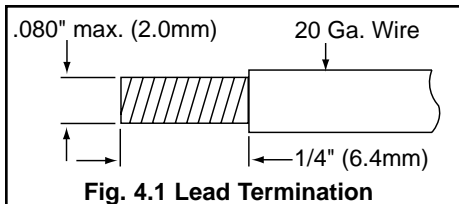
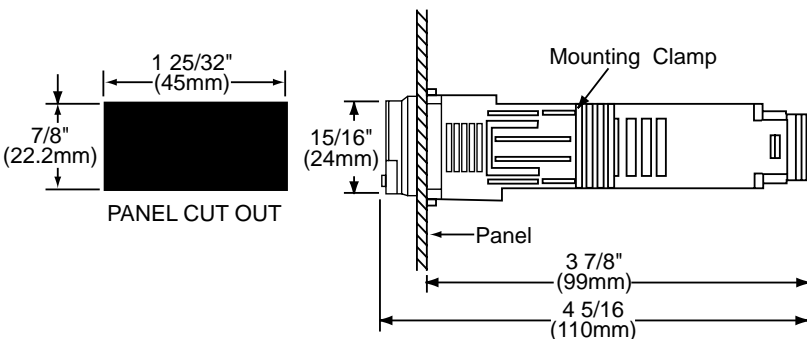
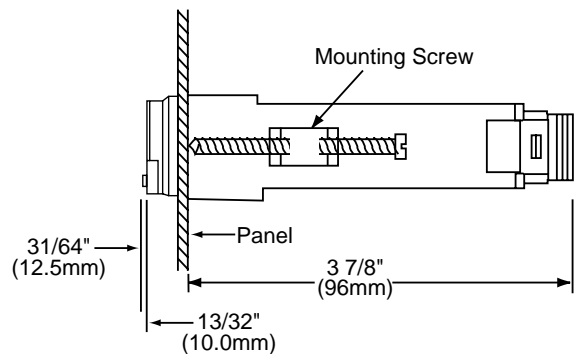

Fig. 4.1 Lead Termination



Controls are supplied with mounting clamp and mounting screws. Release the mounting clamp by depressing the ends of the clamp together. The mounting screws are to be used in applications that require NEMA 4X rating.

Fig. 4.2 Mounting Diagram

Power Wiring:

Connect terminals as shown in Figure 4.3. The power switch S1 and Fuse F1 are included for illustrative purpose only. Refer to Figures 4.4, 4.5, 4.6, 4.7 on the following pages for sample wiring diagrams.

Input Wiring:

Connect the appropriate sensor to terminals 8, 9, 10, 11 or 12 as illustrated in Figure 4.3. Verify that the instrument is selected for the correct sensor and the correct polarity is observed at both the sensor-end and instrument-end of the cable. Do not run sensor cables in the same conduit or wiring trough as the power lines, because the low level signal is noise sensitive.

When wiring the thermocouple, check the thermocouple and extension wire (compensating cable) to make sure they conform to the appropriate thermocouple type specified by the instrument. Extension wires must be the same alloy and polarity as the thermocouple. The total lead resistance should not exceed 100 ohms for accurate measurements. One hundred ohms of lead resistance will introduce a 1°F (0.5°C) error.

For wiring 3 wire RTD (Resistance Temperature Detector) all leads connecting the RTD to the controller must be the same gauge and material. If the RTD is a 3 wire device, install the two common wires of the RTD to terminals 10 and 11. If a 2 wire RTD is to be used, install a jumper between terminals 10 and 11.

See page 21 for instructions to re-range the input to volts, milli-volts or milli-amps.

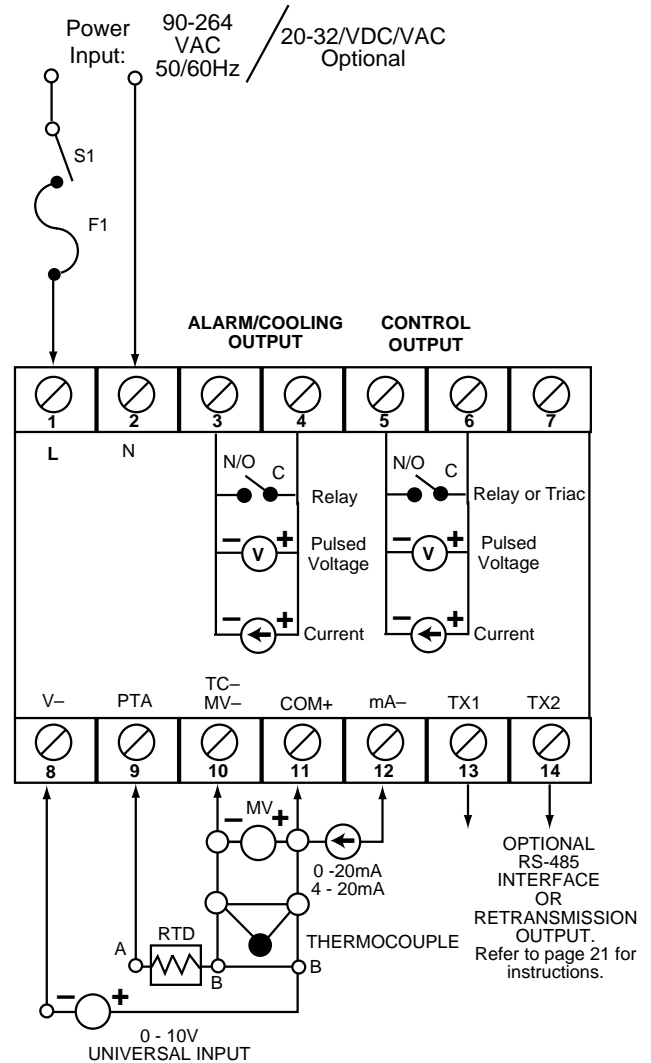

Table 4.1 International Thermocouple Cable Color Codes

Figure 4.3 Rear Terminal Connections

Thermocouple Type	Cable Material	American ANSI	British BS 1843	German DIN 43710	French NFE 18001
J	Iron/Constantan	+ white - red * black	+ yellow - blue * black	+ red - blue * blue	+ yellow - black * black
K	Chromel/Alumel	+ yellow - red * yellow	+ brown - black * red	+ red - green * green	+ yellow - purple * yellow
T	Copper/Constantan	+ blue - red * blue	+ white - blue * blue	+ red - brown * brown	+ yellow - black * black
R S	Platinum/Rhodium	+ black - red * green	+ white - blue * green	+ red - white * white	+ yellow - green * green
B	Platinum/Rhodium	+ grey - red * grey		+ red - grey * grey	

* Color of overall sheath

Chromel® and Alumel® are registered trademarks of Hoskins Mfg. Co.

Typical Wiring Diagrams

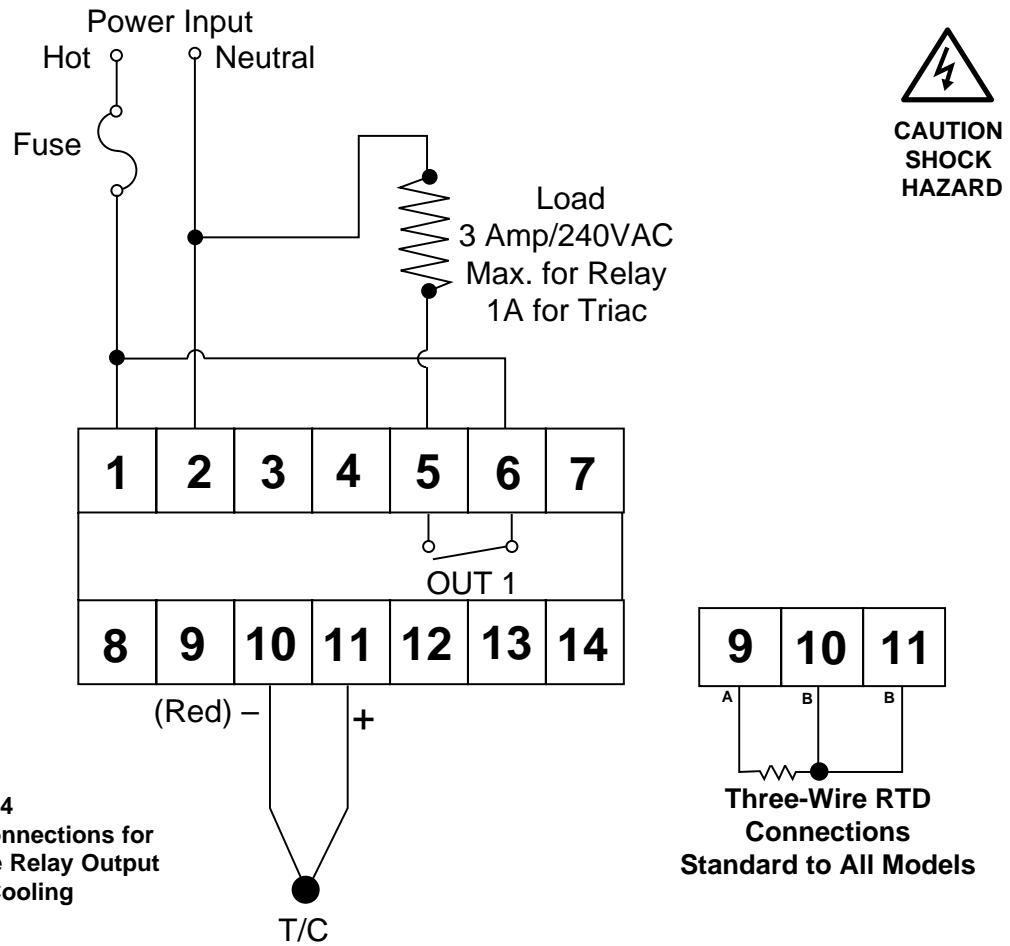

Figure 4.4
Example of wiring connections for
ETR-3200-1211 Single Relay Output
No Alarm or Cooling

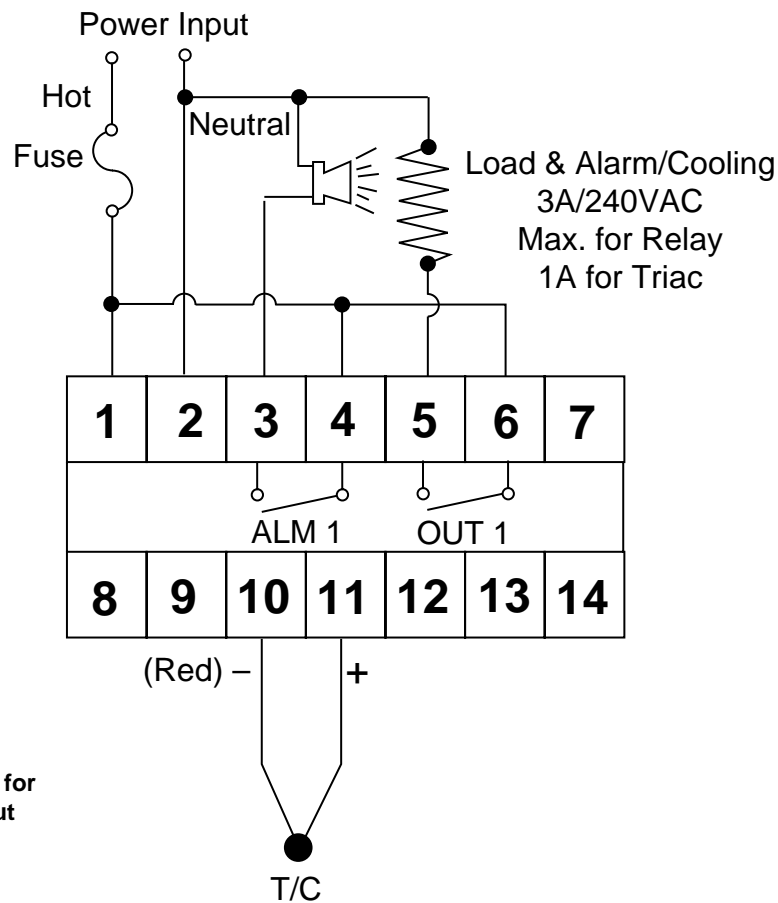

Figure 4.5
Example of wiring connections for
ETR-3200-1221 Heating Output
with Alarm/Cooling

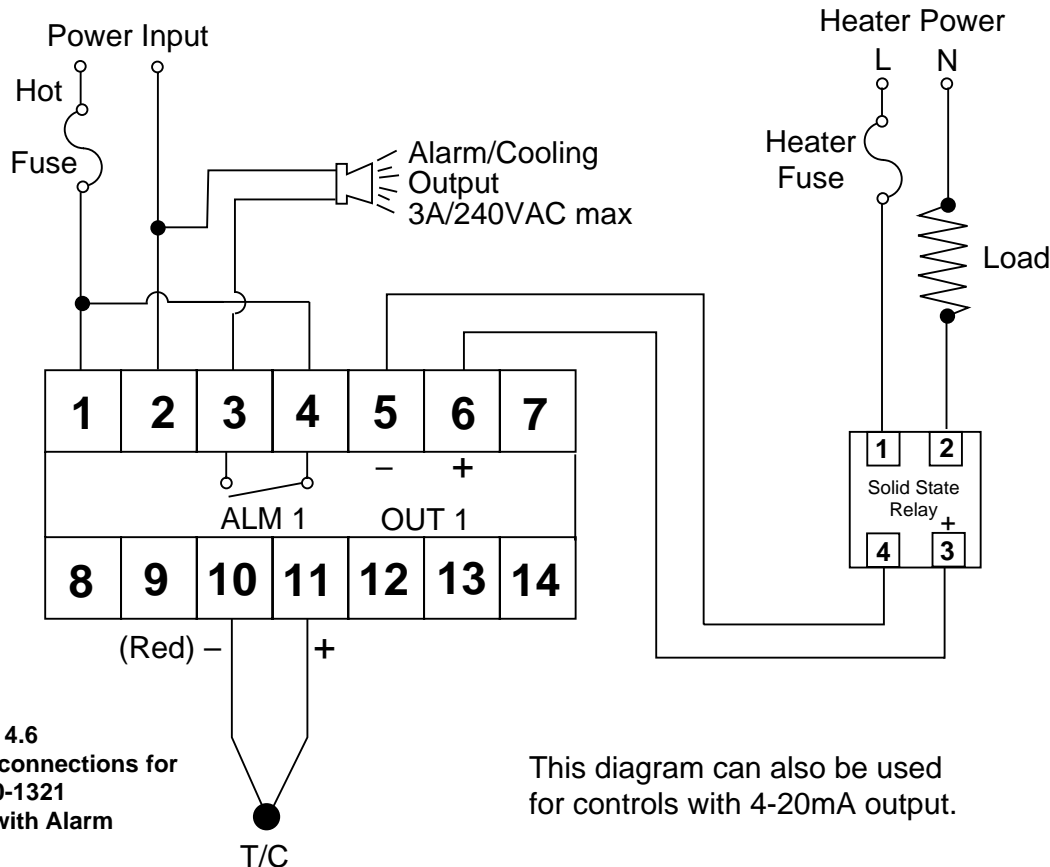

Figure 4.6
 Example of wiring connections for
 ETR-3200-1321
 SSR Output with Alarm

This diagram can also be used
 for controls with 4-20mA output.

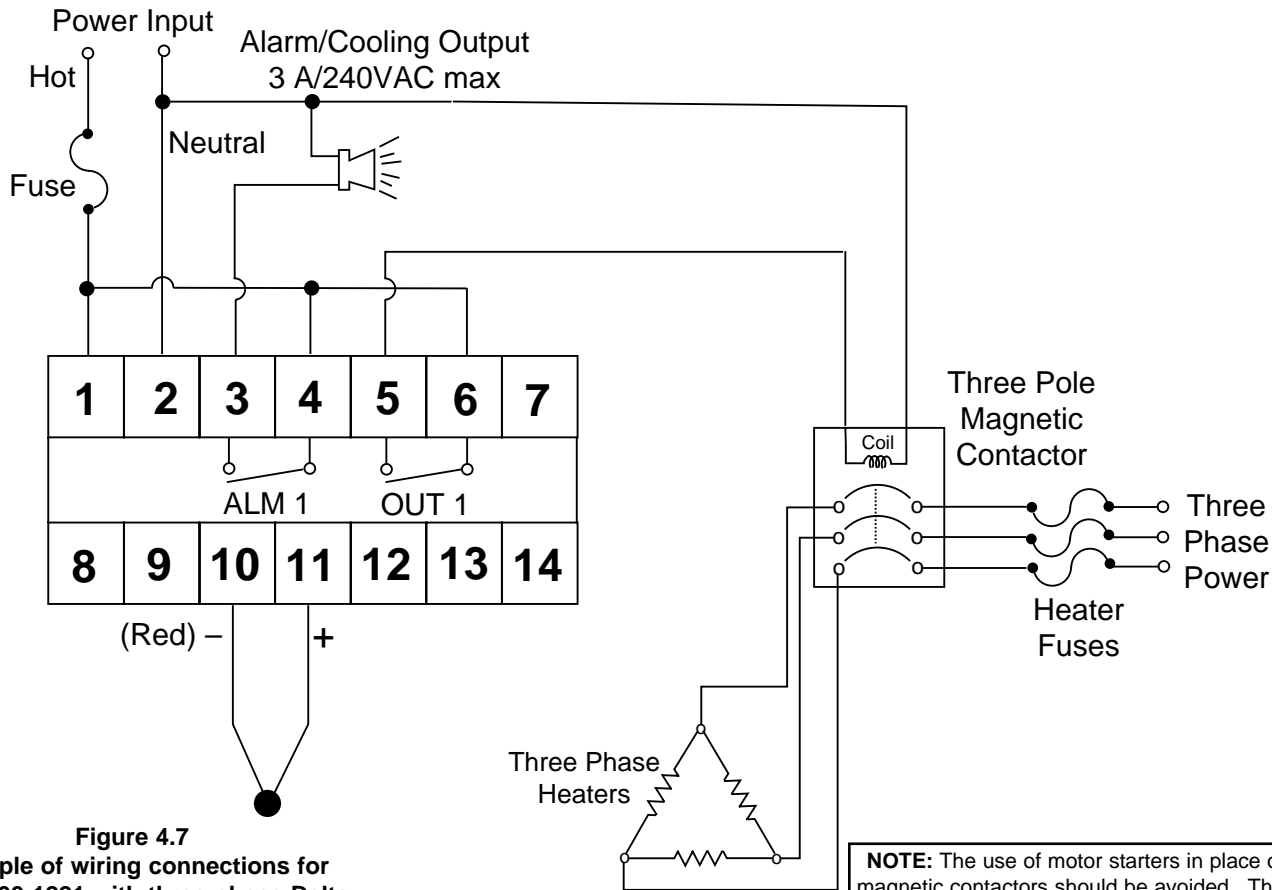

Figure 4.7
 Example of wiring connections for
 ETR-3200-1221 with three phase Delta
 Heater Load and Alarm/Cooling

NOTE: The use of motor starters in place of magnetic contactors should be avoided. They have very large inductive loads that can damage the controller's relay.

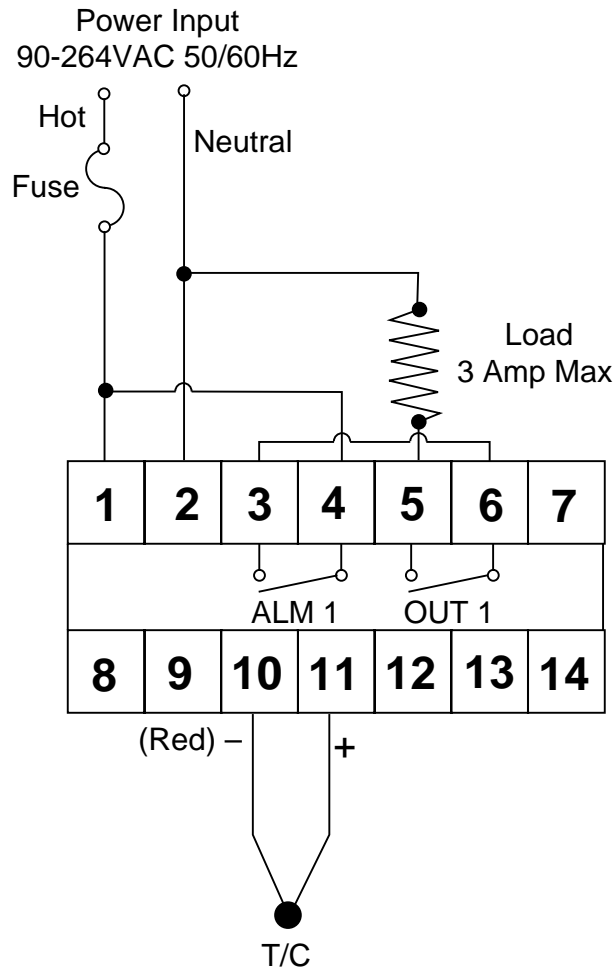

Figure 4.8
ETR-3200-1221
Ramp and Soak
R.I.S.F = t o o F

Output Wiring:

Five different types of output devices can be used from output one. Relay, Triac, current, voltage and pulsed voltage provide a variety of control applications, Verify that the output device is correctly selected to meet your application requirements and make certain the ratings of the output devices are not exceeded before wiring the system.

The external connections depend on what type of output is installed. Pulsed voltage output is not isolated from the internal circuits of the instrument.

Sensor Placement

Proper sensor placement can eliminate many problems in a control system. The probe should be placed so that it can detect any temperature change with minimal thermal lag. In a process that requires fairly constant heat output, the probe should be placed close to the heater. In processes where the heat demand is variable, the probe should be closer to the work area. Some experimenting with probe location is often required to find this optimum position.

In a liquid process, addition of a stirrer will help to eliminate thermal lag. Since the thermocouple is basically a point measuring device, placing more than one thermocouple in parallel will provide an average temperature reading and produce better results in most air heated processes.



Proper sensor type is also a very important factor in obtaining precise measurements. The sensor must have the correct temperature range to meet the process requirements. In special processes the sensor might have to have different requirements such as leak-proof, anti-vibration, antiseptic, etc.





Standard thermocouple sensor limits of error are ± 4 degrees F (± 2 degrees C) or 0.75% of sensed temperature (half that for special) plus drift caused by improper protection or over-temperature occurrence. This error is far greater than controller error and cannot be corrected at the sensor except by proper selection and replacement.











When installation has been completed, the clear protective film can be removed from the faceplate.

Section 5: OPERATION



Table 5.1 Keypad Operation



TOUCHKEYS	FUNCTION	DESCRIPTION
	Scroll Key	Advances the display to the desired parameter. Parameters advance continuously and cyclically by pressing this key. The value of the parameter will be displayed after 2 seconds.
	Up Key	1. Increases the value of a numerical parameter. 2. Selects a desired item in the engineering level.
	Down Key	1. Decreases the value of a numerical parameter. 2. Selects a desired item in the engineering level.

To change the set point or another parameter, tap the  or  key quickly. This will brighten the individual digit of the display. Once the desired digit is brighter, simply hold down the  or  key to increase or decrease the value.

Press  for 4 seconds.	Long Scroll/ Enter Key	1. Selects the parameters in higher security level. 2. Actuates the selected program when in engineering level.
Press  and 	Reverse Scroll/ Calibration Verification Key	1. Selects the parameters in a reverse direction during parameter scrolling. 2. Verifies the display accuracy for various input types during calibration.
Press  and  for 4 seconds.	Lock Key	Disables keypad operation to protect all parameters from being tampered with.
Press  and 	Engineering Level Key	Selects the Engineering level. Scrolls through the Engineering Programs.
Press  and 	Reset (Exit) Key Unlock Key	1. Resets the control to its normal status. 2. Unlocks keypad operation. 3. Exits the engineering level program. 4. Stops the Autotuning function.
Press  and  for 4 seconds.	Autotune Key	Starts the Autotune function. Note description on Page 16.

ETR-3200 TOUCH KEY DESCRIPTIONS:

To move from one level of parameters to another. Scroll to the end of the level. Hold down the  key, the display will flash, once the display stops flashing, release the  key.

To return from any parameter to the process and set point values, press the  and  keys simultaneously.

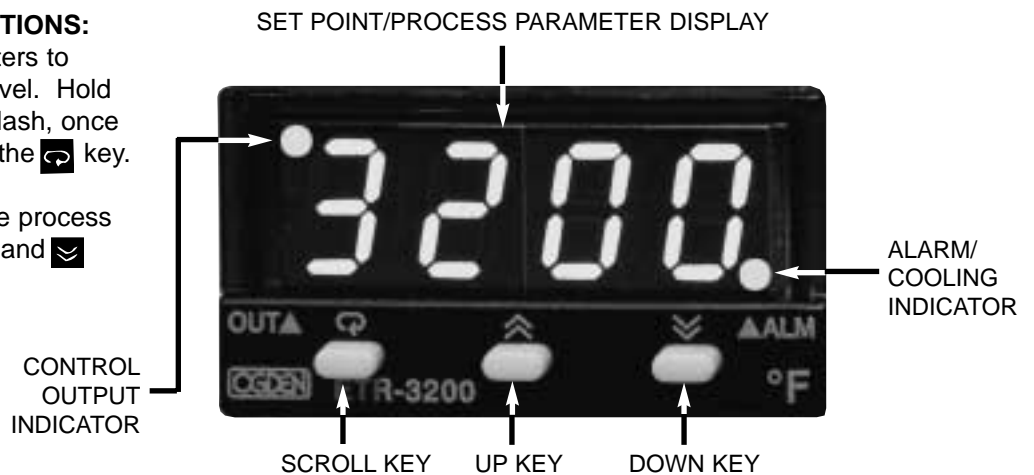

**PROCESS VALUE
SET POINT VALUE**

**Table 5.2 Control Function
and Display Flow Chart
(OPERATOR LEVEL)**

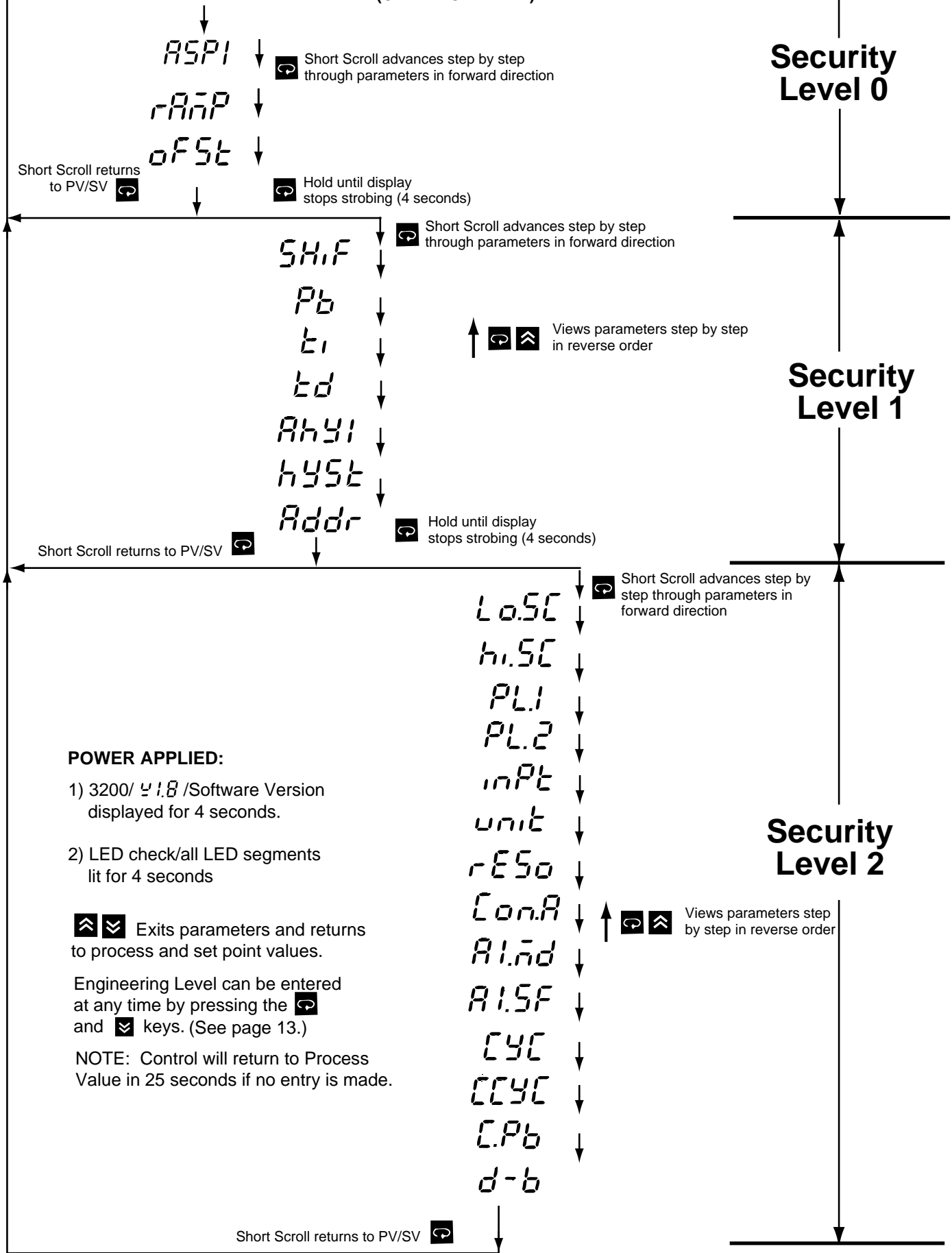

Security Level 0

Security Level 1

Security Level 2

POWER APPLIED:

- 1) 3200/ *v1.8* /Software Version displayed for 4 seconds.
- 2) LED check/all LED segments lit for 4 seconds

Exits parameters and returns to process and set point values.

Engineering Level can be entered at any time by pressing the and keys. (See page 13.)

NOTE: Control will return to Process Value in 25 seconds if no entry is made.

Short Scroll returns to PV/SV

Table 5.3 Index Code (Menu) Descriptions (OPERATOR LEVEL) NOTE: Further parameter definitions on page 15.

Security Levels	Display Code:	Description:	Adjusting Range:	Default Setting:
0		Set point Value of Control	Low scale to high scale value. (L o S C, h i, S C). Press the or key to display set point.	212
	ASPI	Alarm 1 Set Point Value, Dwell Time R1.5F = t o o n or t o o F/Minutes	Trip Point within High/Low scale or 0 - 9999 minutes (for Dwell Time)	18°F (10.0°C)
	rAnP	Ramp Rate	0 - 99.99°F/minute (0 - 55.55°C/minute)	0.00
	oFSt	Offset Value for Manual Reset (Integral Time TI = 0)	0 - 100% Only functional if Integral is set to 0.	0.0
1	ShiF	Display Shift	-199° to 199°F (-111 - 111°C) (Refer to page 20)	0
	Pb	Proportional Band of Output 1	0 - 360°F (0-200.0 °C) O: for ON-OFF control (Refer to Page 16)	18°F (10.0°C)
	t1	Integral (Reset) Time of Output 1	0 - 3600 seconds	120
	td	Derivative (Rate) Time of Output 1	0 - 1000 seconds	40
	AhY1	Hysteresis of Alarm 1	0 - 19°F (0 - 11 °C)	0
	hYSt	Hysteresis of ON-OFF control	0 - 19°F (1 - 11 °C)	0
	Addr	Interface Address	0 - 40	0
2	LoSC	Low Scale of Range. Adjust for your process	Minimum value for the selected Input (INPT) to High Scale (HISC)	0
	hiSC	High Scale of Range. Adjust for your process	Low Scale (LOSC) to maximum value for the selected Input (INPT)	999
	PL1	Power Limit of Output 1	0 - 100%	100%
	PL2	Power Limit of Output 2	0 - 100%	100%
	inPt	Input Type Selection	J-tC = J Type T/C K-tC = K Type T/C T-tC = T Type T/C E-tC = E Type T/C B-tC = B Type T/C R-tC = R Type T/C S-tC = S Type T/C N-tC = N Type T/C Pt d n = PT100 DIN Pt JS = PT100 JIS 4-20 = 4-20 mA 0-20 = 0-20 mA 0-1V 0-1V 0-5V = 0-5V 1-5V = 1-5V 0-10V 0-10V	J-tC
	unit	Display Units	°C = degree C °F = degree F P U = process units (Engineering Units)	°F
	rESo	Resolution	no d P = No decimal point used i d P = 1 Digit decimal 2 d P = 2 Digit decimal (only for Linear Voltage or Current Input)	no d P
	Con.A	Control Action of Output 1	d i r t = Direct (Cooling) Action r e v r = Reverse (Heating) Action	r e v r
	Alnd	Alarm 1 Mode	d y h i = Deviation High Alarm d y l o = Deviation Low Alarm d b h i = Deviation Band High Alarm d b l o = Deviation Band Low Alarm F S h i = Full Scale High Alarm F S l o = Full Scale Low Alarm	d y h i
	R1SF	Alarm 1 Special Function	no n E = No Special Function l t c h = Alarm with Latch Function h o l d = Alarm with Hold Function l t h o = Alarm with Latch & Hold Function t o o n = Dwell Timer ON as Time Out t o o F = Dwell Timer OFF as Time Out c o o l = Proportional Cooling	no n E
	CYC	Proportional Cycle Time of Output 1	0 - 99 Seconds, 0 for Linear current/voltage output	20 For Relay Output
	C.CYC	Cooling Cycle Time	0 - 99 Seconds, 0 for Linear current/voltage output	20 For Relay Output
	C.Pb	Cooling P Band	0 - 360°F (0 - 200°C)	18°F (10.0°C)
d-b	Dead Band for pB and CPB	-199 - 199°F (-111 - 111°C)	0	

Table 5.4 Parameter Record Sheet (OPERATOR LEVEL)

CONTROL NO.	DATE	PARAMETER					
		SET POINT VALUE					
		<i>ASPI</i> ALARM SET POINT 1					
		<i>rAMP</i> RAMP RATE					
		<i>oFSt</i> OFFSET					
		<i>ShiF</i> DISPLAY SHIFT					
		<i>Pb</i> PROPORTIONAL BAND/HEAT					
		<i>t_i</i> INTEGRAL TIME					
		<i>t_d</i> DERIVATIVE TIME					
		<i>AhY1</i> HYSTERESIS ALARM 1					
		<i>hYSt</i> HYSTERESIS ON/OFF					
		<i>Addr</i> ADDRESS					
		<i>Lo.SC</i> LOW LIMIT OF RANGE					
		<i>hi.SC</i> HIGH LIMIT OF RANGE					
		<i>PL1</i> POWER LIMIT OUTPUT 1					
		<i>PL2</i> POWER LIMIT OUTPUT 2					
		<i>inPt</i> INPUT TYPE					
		<i>unit</i> UNIT TYPE					
		<i>rESo</i> RESOLUTION					
		<i>Con.A</i> CONTROL ACTION					
		<i>AlAd</i> ALARM MODE 1					
		<i>AlSF</i> ALARM 1 SPECIAL FUNCTION					
		<i>CYC</i> PROPORTIONAL CYCLE TIME					
		<i>CCYC</i> COOLING CYCLE TIME					
		<i>C.Pb</i> COOLING PROPORTIONAL BAND					
		<i>d-b</i> DEADBAND					

Table 5.5 Engineering Level

The engineering level can be entered at any time by pressing the keys. This level contains six parameters for control configuration and options. The parameters are defined as:

Manual Mode (hand control) – This feature is used if the sensor fails. The control can now be used as an on-off proportional timer to control the load until a new sensor can be installed. The setting for heating or cooling is 0 - 100% of the proportional cycle time.

Peak Process Values – The minimum and maximum peak values of the process are indicated here.

Calibrate A-D Converter – This parameter is used during the calibration procedure.

Fail Safe – This defines the status of the outputs if the sensor fails.

Lock Parameters – Levels 0, 1 or 2 in the operators level can be locked-out to prevent unauthorized tampering.

Configuration Level – This feature allows parameters to change levels (0, 1 or 2) in the operators level. The purpose of this is to allow only selected parameters to be adjustable and all the others to be locked-out. For example, if only the set point is to remain un-locked, all the other parameters in level 0 can be moved to level 1. Then lock out level 1 and 2.

Press the keys to exit the engineering level.

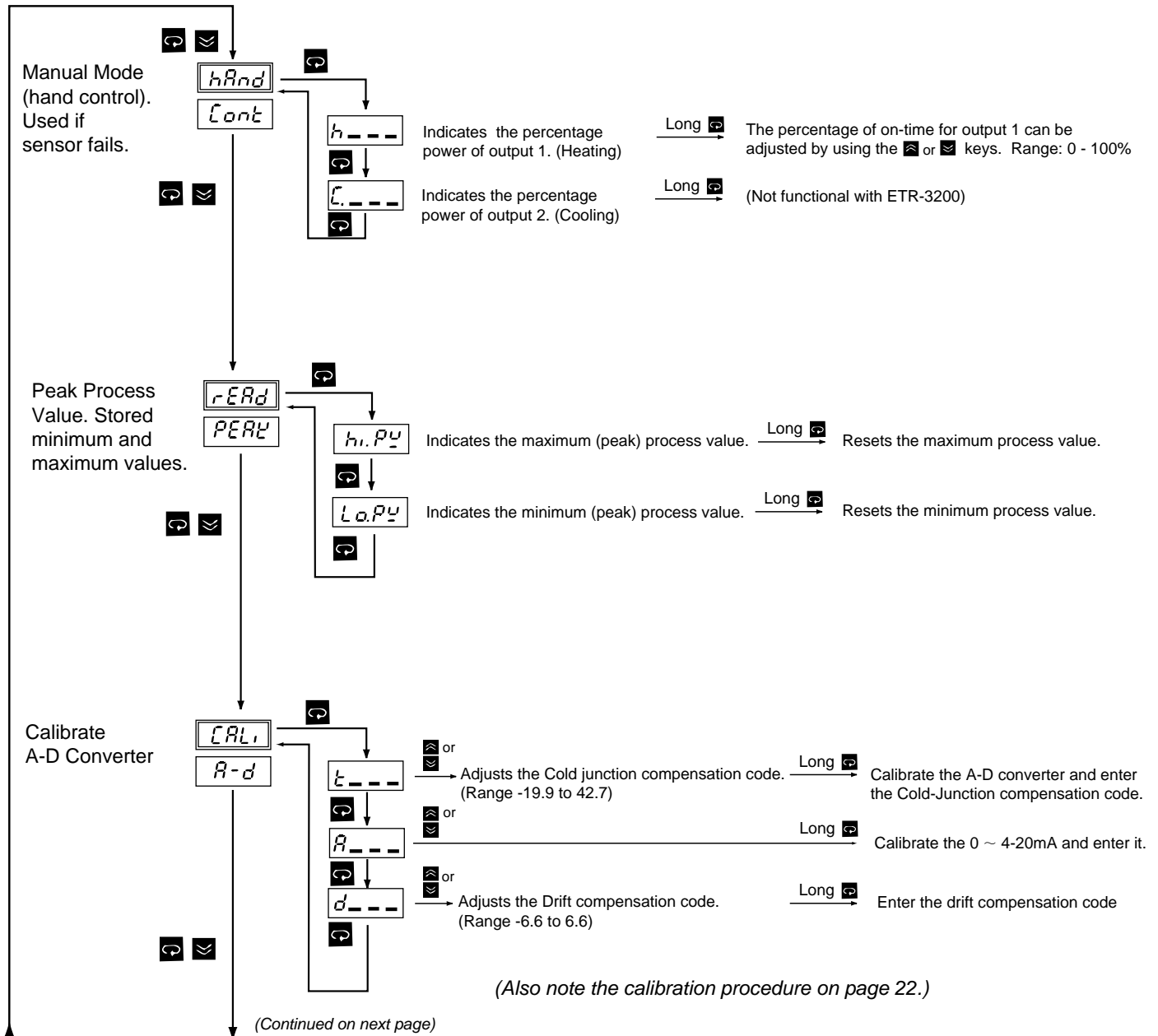

(Engineering Level continued)

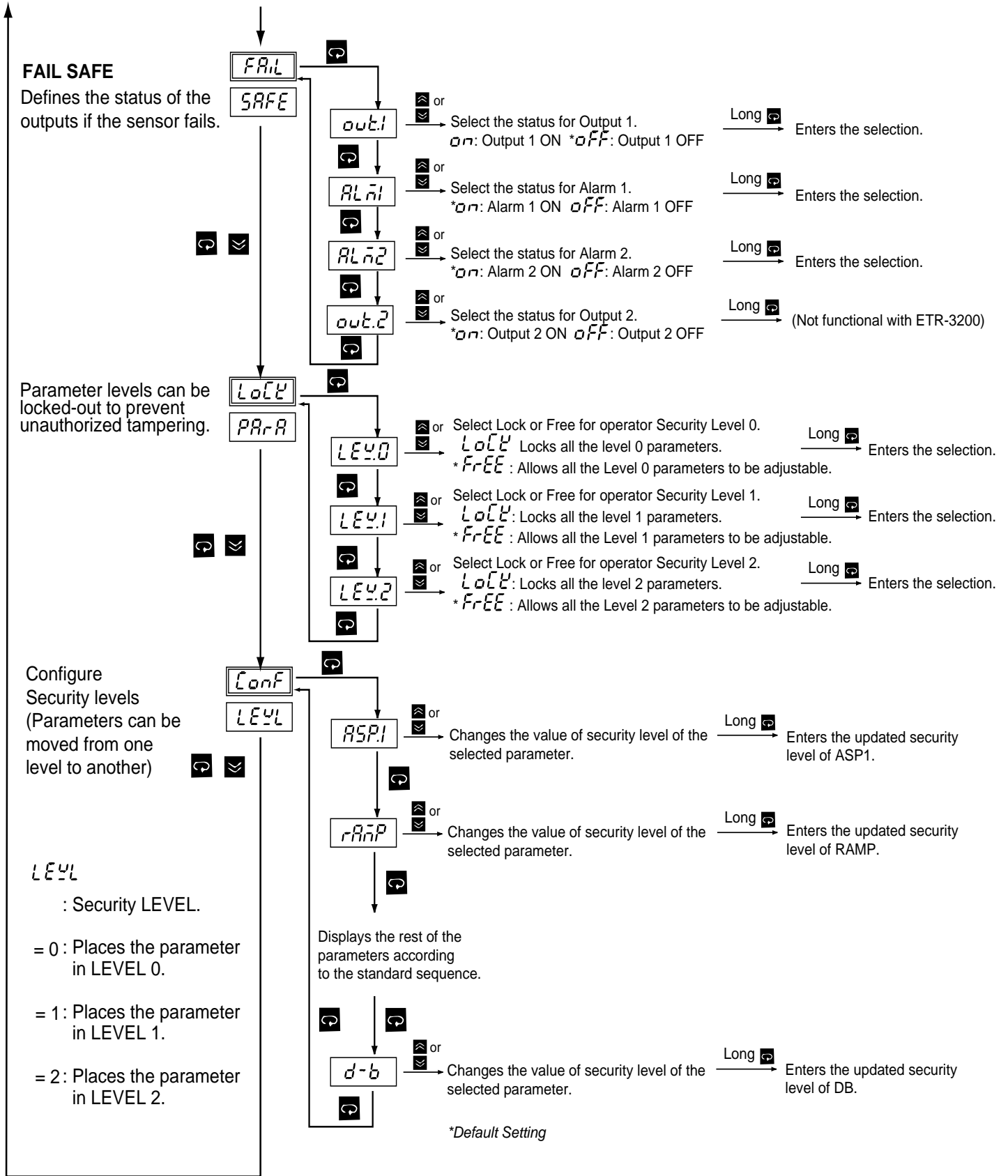

Press the keys to exit the engineering level.

Operator Level Parameter Definitions:

PV - Process Value This is the temperature (or other process variable) as measured at the sensor. This will indicate a value within the range between the low scale (Lo.SC) and high scale value (hi.SC). This indication will read an error code if the temperature (process variable) goes out of the preset span. Note items 6 and 7 of the troubleshooting guide on page 24 for the error code descriptions.

SV - Set Point Value This parameter is the desired set point of the process. It can be adjusted within the range defined by the low scale (Lo.SC) and high scale value (hi.SC). The span adjustments can be used to limit the set point of the controller.

ASP1 - Alarm 1 Set Point Value or Dwell Time This sets the points at which alarm 1 will energize if A1.SF (alarm 1 special function) is set for an alarm function. If A1.SF is selected for the dwell timer function (toon or toof), then this becomes the timer setting in minutes. The dwell timer starts counting when the process value reaches the set point value. Note page 19 for more information.

rAMP - Ramp Rate This controls the heat-up and cool-down rate of the process. This setting is in degrees per minute.

oFSE - Offset Value This parameter is only functional if the integral time (automatic reset) is set to zero. The oFSE then functions the same as manual reset to correct the process temperature to the set point temperature. If the process temperature stabilizes below the set point, then set a positive amount of oFSE. If the process temperature stabilizes above the set point, set a negative amount of oFSE. Wait for the system to stabilize and make further adjustments as required.

ShiF - Display Shift A value entered here will be added or subtracted from the process value. This offset can be used as a correction factor if the sensor does not read the same temperature as the item being sensed. Note page 21 for more information.

Pb, Ei and Ed - PID Values Proportional band, Integral (reset) and Derivative (rate) time constants. These must be set as close as possible to the process application requirements. Note page 16 for more information.

AhY1 - Hysteresis of Alarm 1 The values entered here define the deadbands for the alarm. The alarm will not change state until the temperature is outside of the deadband.

hySE - Hysteresis of On-Off Control This parameter defines the deadband when on-off control is used and PID control has been disabled. For on-off control, set Pb, Ei and Ed to 0. The output on a relay control will not change state until the temperature is outside the

deadband. Note page 16 for further information.

Addr - Interface Address For external communications with a computer or retransmission output setting.

Lo.SC, hi.SC - Low/High Scale Range These parameters are used to define the range (span) of the control. These should be set for the requirements and safety of your process. Refer to Initial operation on page 16 for further information. If inputs other than thermocouples or RTDs are required, refer to page 21 for directions.

PL.1, PL.2 - Power Limit These parameters are used to limit the output percentage of power for heating or cooling. If the control has relay or pulsed voltage outputs, then the percentage of "on" time will be decreased. The actual output levels will be decreased if the control has linear current (4-20mA) or linear voltage outputs.

inPE - Input Type This parameter is used to program the control to the type of input sensor used.

uniE - Process Units This parameter is used to set the display in degrees F, C or blank for engineering units.

rESo - Display Resolution This parameter is used to place a decimal point in the process and set point values. A two-place decimal point can only be set if the uniE adjustment is set to engineering units (PU).

Con.A - Control Action of Output 1 This parameter selects heating (reverse) or cooling (direct) action for output 1.

A1.Md - Alarm Mode Selection for Alarm 1 and This adjustment sets the type of alarm required: deviation alarm, band alarm or process alarm. Refer to page 19 for more information.

A1.SF - Alarm 1 Special Function This selects special functions required for use with alarm 1. The special functions include latching alarms, hold (inhibited) function or dwell timer function. Refer to page 19 for more information on alarms.

CyC - Proportional Cycle Time of Output 1 This sets the proportional cycle time for output 1. This should be set according to the type of output device used. For mechanical relays, cycle times of 15 to 20 seconds are used. For solid-state relays, set this adjustment to 1 or 0. For 4-20mA or other linear outputs set this to 0.

CCyC - Cooling Cycle Time Only used if A1.SF (alarm 2 special function) has been set for cooling. Use the same settings as the above paragraph.

C.Pb, d-b Cooling Proportional Band, Cooling Deadband Only used if A1.SF (alarm 1 special function) has been set for cooling. Refer to page 21 for further information on the settings to be used for cooling output.

Initial Operation:

When the control has been wired you can apply power. The display should indicate 2220, software version and LED lamp illumination test. The temperature (or other process variable) as measured at the sensor should be indicated by the PV display. The thermocouple is wired in reverse if the indicated temperature decreases as the temperature at the thermocouple increases. While making initial settings to configure the control, the set point should be lowered to a value (eg. 30°F) to assure the heaters will not be energized. This will allow time to make any adjustments of the parameters in the operators or engineering level.



During this initial set-up, alarm points and other settings can be made. The low limit and high limit range settings (Lo.SC) and (hi.SC) should be adjusted to your process. This sets the range (span) of the control. The set point cannot be adjusted out of this range.

Generally, for plastics processing and packaging, a span of 0 - 800°F is common. If oils are used, a lower span such as 0 -300°F should be entered.

When the configuration settings have been made, you can return to the PV/SV level. Adjust the required process set point. The red "out" lamp should illuminate, indicating the heaters have been powered.

Autotuning:

The autotune function "teaches" the controller the main characteristics of the process. It "learns" by cycling the output on and off. The process will oscillate around the set point during autotuning. Note the diagram below:

Adjust the set point to a lower value if overshoot beyond the normal process value may cause damage. The results are measured and used to calculate the optimum PID values. It should not have to be repeated on the same process. The autotune function starts by depressing the  and  keys for 4 seconds; then

release. The process value display will flash on and off indicating the control is in the autotune mode. No other adjustments can be made to the system while the control is autotuning. The control will finish autotuning by itself and the correct PID values will be entered into the control's memory.

Autotuning will not function if the control has been configured from PID to ON-OFF. For electric heating PID is usually recommended.

Autotuning may not give satisfactory results and hold a close temperature on all applications. If this occurs, you can change the PID values manually using the three charts in Figure 5.2 on the top of the next page for a guide. It is recommended to change only one parameter at a time, so the results of that change can be clearly noted.

Adjusting PID Parameters:

The PID parameters can be reviewed by operating the scroll key and noting whether the values are reasonable or not. Examine the controller's result. Modify the PID values until the control quality is acceptable.

ON-OFF Control:

On-off control action is recommended when continuous cycling of the load cannot be used. Examples are mechanical solenoids, large contactors and valves. For on-off control, set the following parameters to zero: proportional band; integral; derivative and offset (oFSE). The hysteresis (hySE) adjustment is now used to set the deadband. The larger the hysteresis is set, the larger the deadband will be. A large deadband will cause the contactor (or other device) to switch less often, but the process will oscillate farther from the set point. This setting is measured in degrees.

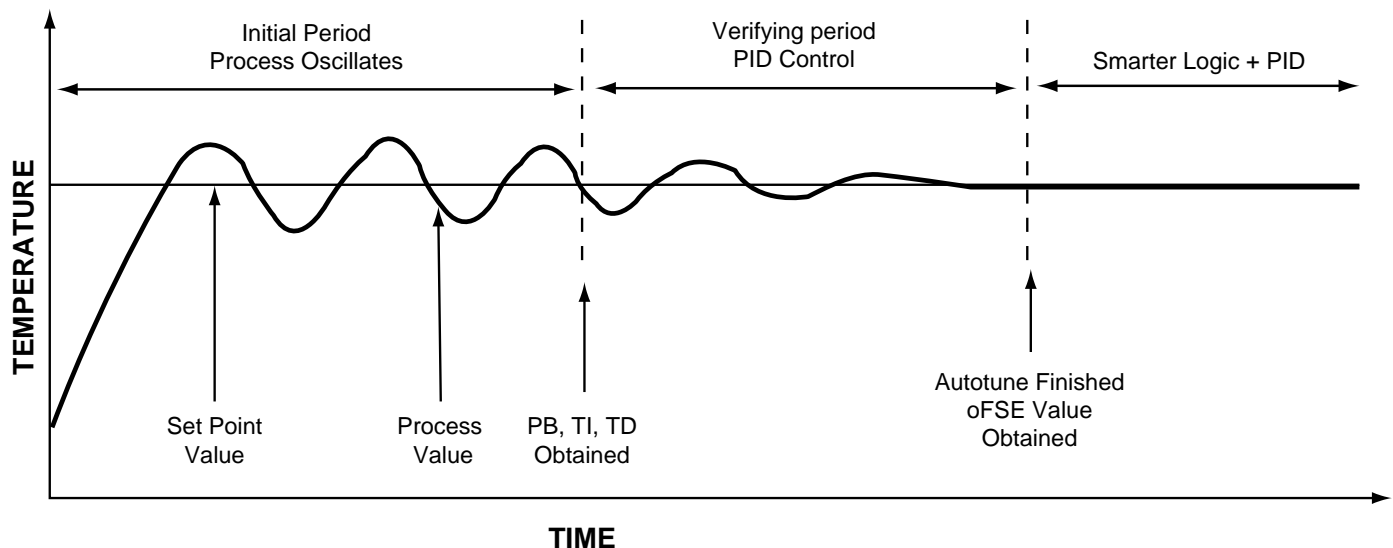

Figure 5.1 Autotuning

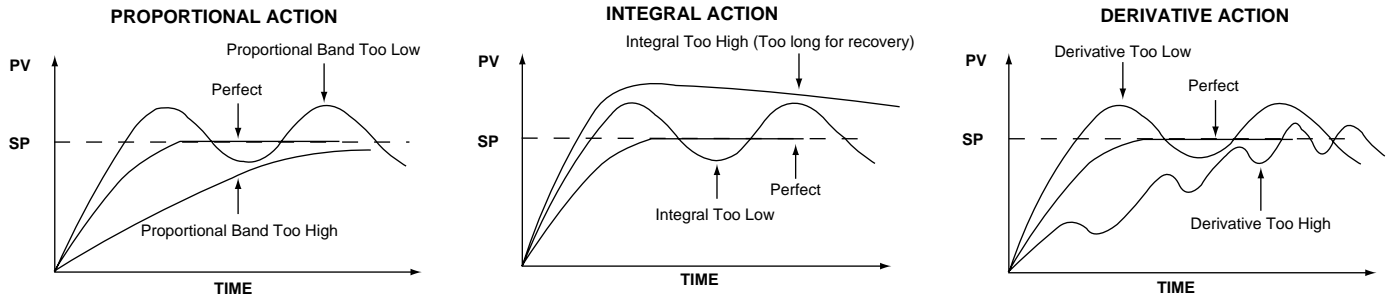

Fig. 5.2 Effects of PID Adjustment of Process Response

The proportional band (Pb) is a temperature band expressed in degrees. When the process temperature is within this band, the time proportioning function is active.

Integral action (automatic reset) corrects for offset (load error) for load variations. Anti-reset wind-up inhibition prevents integral action from occurring outside of the proportional band. Software antisaturation minimizes process oscillation when the load changes

Derivative action is adjusted to match the response time of the process and to compensate the integral action. Correct adjustment provides power output compensation for process load variations. It also minimizes overshoot and oscillations at start up or in large process upsets.

Manual Tuning Procedures:

For some systems it is difficult to execute automatic tuning or the automatic tuning results are not satisfactory. The following steps can then be used for initial tuning of a three-mode control:

- Step 1: Adjust the integral and derivative values to 0. This inhibits the rate and reset action.
- Step 2: Set an arbitrary value of proportional band and monitor the control results.
- Step 3: If the original setting introduces a large process oscillation then gradually increase the proportional band until the oscillation disappears.
- Step 4: If the original setting does not introduce process

oscillations then gradually decrease the proportional band until steady cycling is observed. Record this important proportional band percentage (Pc).

- Step 5: Time the period of steady cycling. Record this critical period Tc. The PID parameters are determined as:

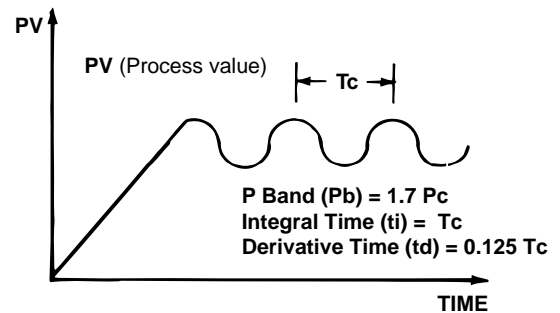

Fig. 5.3 Steady State Cycling

This method was developed by Ziegler and Nichols.

If you are unfamiliar with tuning PID Controllers, we suggest that you obtain and become familiar with the following reference material: *Tuning of Industrial Control Systems* by A.R. Corripio ISBN: 1-55617-253-2-Q. Available from: ISA Publications and Training Aids, Phone: 919-549-8411.

This method should be performed with a temperature chart recorder.

Fig. 5.4 Response of a Typical Control System Using Various Modes of Control

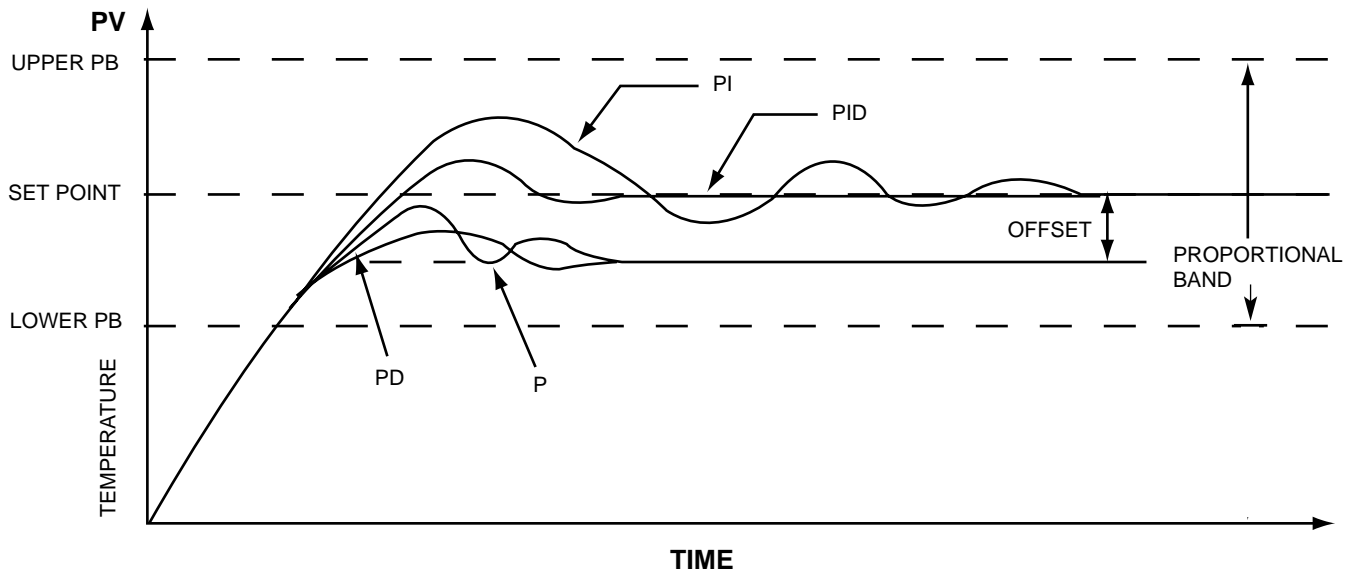

Table 5.6 Tuning Guide

ADJUSTMENT SEQUENCE:	SYMPTOM:	SOLUTION:
1.) Proportional Band	Slow Response	Decrease P Band (Pb)
	High Overshoot or Oscillations	Increase P Band (Pb)
2.) Integral Time (Reset)	Slow Response	Increase Reset (i.e. Decrease Integral Time)
	Instability or Oscillations	Decrease Reset (i.e. Increase Integral Time)
3.) Derivative Time (Rate)	Slow Response or Oscillations	Decrease Rate (i.e. Decrease Derivative Time)
	High Overshoot	Increase Rate (i.e. Increase Derivative Time)

PID Control

For various applications the controller can be used as P control only (set integral = 0, derivative = 0); PI control (set derivative = 0), PD control (set integral = 0), and PID control.

Figure 5.4, on page 17, represents the response of a typical control system using various modes of control.

- 1.) P control results in a response showing a deviation (offset), a high overshoot and a moderate period of oscillation. In addition, a significant length of time is required before the system ceases to oscillate.
- 2.) PI control has no offset, but elimination of offset comes at the expense of higher overshoot, larger period of oscillation and a longer time required for oscillations to cease compared with other modes of control.
- 3.) PD control generally brings the system to steady state in the shortest time with the least oscillation. However, it still has offset.
- 4.) PID control is essentially a compromise between the advantages of PI and PD control. Offset is eliminated by the integral action. The derivative action serves to lower offshoot and to eliminate some of the oscillations realized with PI control.

Ramp and Soak Function:

The ETR-3200 can be programmed as a two segment ramp and soak control. The ramp rate, in degrees per minute, is determined by the "rRnSP" setting. The soak function is accomplished by configuring alarm 1 relay as a timer. The heater (or contactor coil) must be wired in series through the alarm 1 relay and the "out 1" relay. Refer to wiring diagram figure 4.8 on page 8. To use this

feature, set A1.SF (alarm 1 special function) to 400F. Set the soak period at ASP1 (alarm 1 set point). The alarm relay will be closed at start-up. It will remain closed until the process temperature has remained at the set point temperature for the time period (minutes) set in ASP1. Note the following example: The ramp rate is set to 20 (degrees per minute), A1.SF is set to 400F and ASP1 to 30 (minutes). When the control is powered, the process will climb at 20 degrees per minute to the set point of 475°F. Once the set point temperature has been reached, the soak timer begins counting. After a time period of 30 minutes has elapsed, the alarm relay 1 will open and the process temperature falls at an uncontrolled rate. This process will repeat every time power has been switched off and on to the controller. Note diagram 1 below.

Single Event (Dwell) Function:

The single event (dwell) function may be used to control external devices such as lights, bells or locks. It could also be used to alert the operator when a guaranteed soak time has been reached. To use this feature, set ASP1 (alarm 1 set point) to the time period (in minutes) of the timer. Set A1.SF (alarm 1 special function) to 400n. The alarm relay will now operate as a timer. The alarm relay will be open at start-up. Once the set point temperature has been reached and the time period set in ASP1 has elapsed, the alarm relay will close. This relay will remain closed until power to the control has been disconnected. The cycle will repeat each time the control has been energized. Other features such as ramp rate can also be used. Note diagram 2 below. The set point is 175°F and the dwell time has been set to 30 minutes.

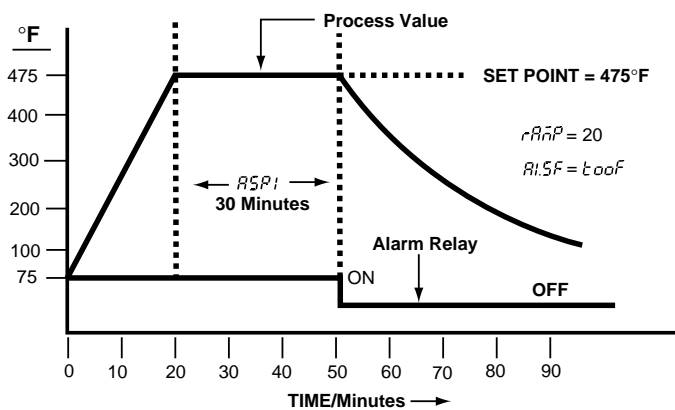

Diagram 1: Ramp and Soak

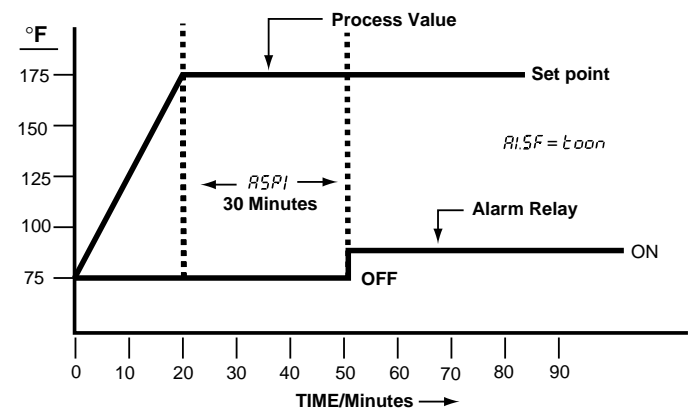

Diagram 2: Single Event

Alarm Modes:

There is one independent alarm available. The alarm modes are selected by designating the alarm types with the parameter: *Al.md*. The alarm special functions (*A1.SF*) can be implemented together with the *Al.md* mode that is selected.

 : Alarm ON

SV = SETPOINT VALUE
ASP1 = Alarm 1 Set Point

Al.md = Alarm 1 Mode

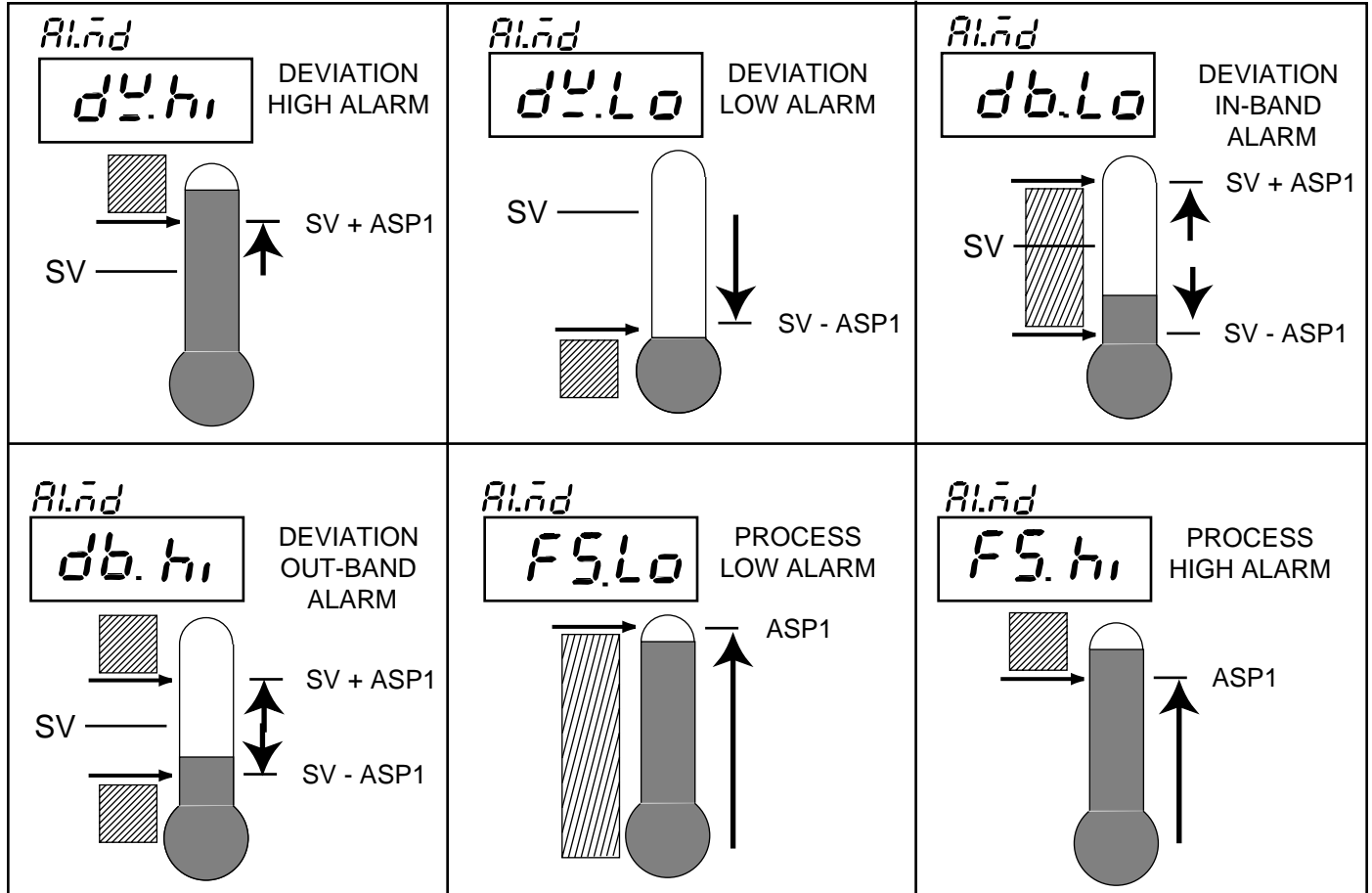

• **ALARM SPECIAL FUNCTIONS: A1.SF**

• **Latch Alarm: A1.SF = lckh**

When the latch mode is selected, the alarm will stay active until the power is reset.

• **Inhibited Alarm: A1.SF = hold**

This mode prevents an alarm at start up. The alarm is enabled only when the Process Value reaches the Set Point (SV).

• **Latch and Inhibited Alarm: A1.SF = lckh**

When selected, the alarm will stay active until the power is reset. The alarm mode is only enabled when the Process Value reached the Set Point Value (SV).

• **Cooling: A1.SF = cool**

Alarm 2 can be designated as a cooling output if heating and cooling operation is desired.

• **Hysteresis (AHY1)**

EXAMPLE: No special function used with (SV) Deviation High Alarm.

SV = 100°F ASP1 = 10°F AHY1 = 4°F

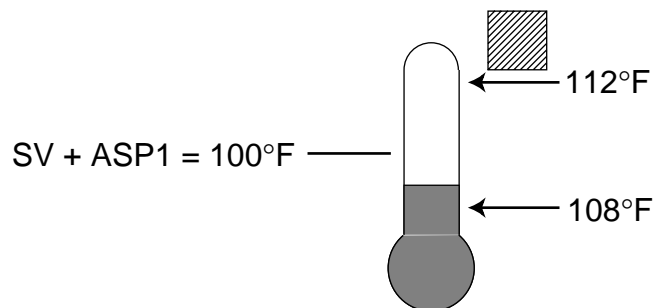

• **Alarm Set Point Ranges**

- Low scale ~ High scale (Full scale Alarms)
- -199 - 199°F (-111 - 111°C) Deviation alarms
- 0-9999 minutes for (A1.SF = toon or toof) Dwell Time

Display Shift

In certain applications it is desirable to shift the controllers indicated value from its actual value. This can be easily accomplished with this control by using the display shift function. Cycle the control to the *SHIF* parameter by using the "Scroll" pushbutton. The number you adjust here, either positive or negative, will be the amount that the process value will be shifted from the actual value. This amount will be the same across the entire range of the control. Note the example stated below.

The desired temperature at the part to be heated is 330 degrees F. In order to achieve that temperature, the controlled value or the temperature at the sensor must be 375 degrees F. Due to the design and position of the components of the system, the sensor could not be placed any closer to the work.

Thermal gradients (different temperatures) are common and necessary to an extent in any thermal system for heat to be transferred from one point to another.

The difference between the two temperatures is 45 degrees F. You should input -45 as to subtract 45 degrees from the actual process value.

Cycle the control back to the process value after making this adjustment.

The display shift will alter the process value only.

The set point must be manually adjusted to 330.



DISPLAY BEFORE INPUT SHIFT



DISPLAY AFTER INPUT SHIFT. ADJUST SET POINT TO 330



DISPLAY AFTER INPUT SHIFT AND SET POINT ADJUSTMENT

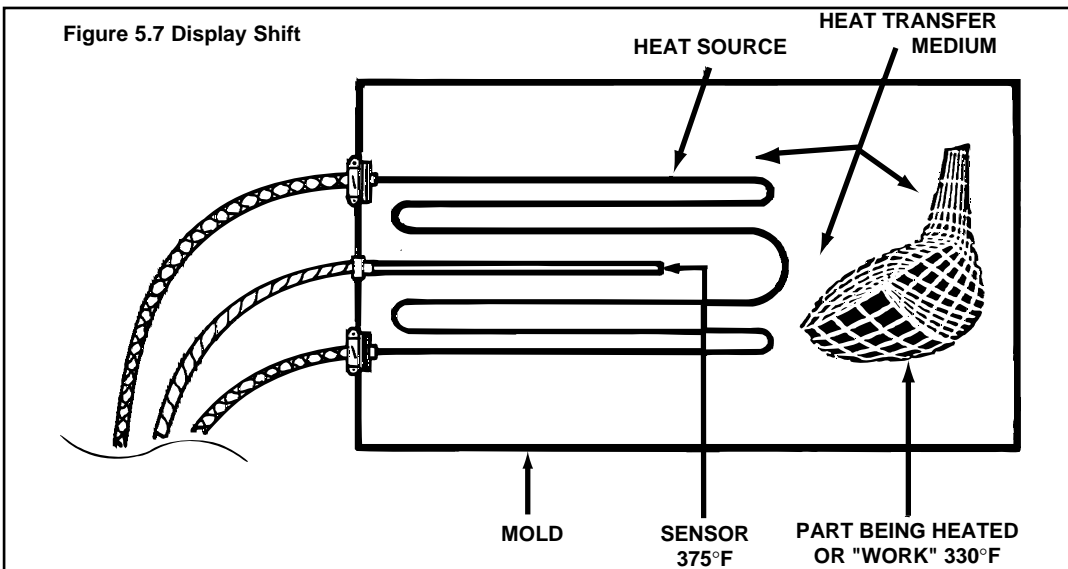

DIRECTIONS FOR USING RETRANSMISSION (TRANSFER) OUTPUT:

The retransmission output of 4-20mA uses terminals 13 and 14. Terminal 13 is positive (+) and 14 is negative (—).

The interface parameter (Addr) is used to select which value is retransmitted. The possible selections are as follows:

192	Retransmit Process Value, 4-20mA	196	Retransmit Process Value, 0-20mA
193	Retransmit Set Point Value, 4-20mA	197	Retransmit Set Point Value, 0-20mA
194	Retransmit Alarm Value 1, 4-20mA	198	Retransmit Alarm Value 1, 0-20mA
195	Retransmit Alarm Value 2, 4-20mA	199	Retransmit Alarm Value 2, 0-20mA

Set the span of the control, low scale (Lo.SC) and high scale (hi.SC) to set the span of the retransmitted output.

FOR EXAMPLE: 0-1000, SPAN Lo.SC set to 0 and hi.SC set to 1000 would transmit 4MA AT 0 and 20MA at 1000.

Cooling Deadband Adjustment:

This adjustment is used on the ETR-3200 to set the point at which the cooling set point is made. The heating proportional band, cooling proportional band and deadband are described in the following chart. Please note that Alarm 1 Special Function (A1.SF) must be set to cool.

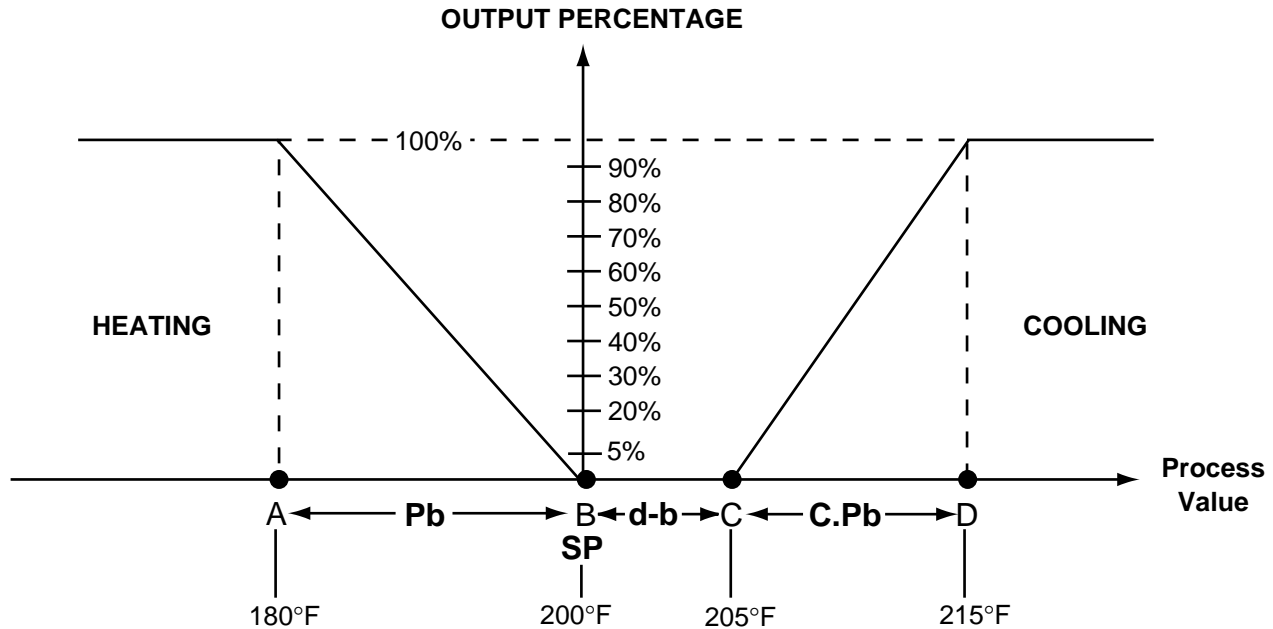

- SP** = Set Point (SV)
- Pb** = Heating Proportional Band
- d-b** = Deadband
- C.Pb** = Cooling Proportional Band

- The points on the chart are:
- A** = SP - Pb
 - B** = SP
 - C** = SP + d-b
 - D** = SP + d-b + C.Pb

An example of the settings of a typical system may be:

- Set Point = 200°F
- Pb = 20°F
- C.Pb = 10°F
- d-b = 5°F

In this example the points on the chart would be:

- A = 180°F SP - Pb = 200 - 20 = 180
- B = 200°F SP
- C = 205°F SP + d-b = 200 + 5 = 205
- D = 215°F SP + d-b + C.Pb = 200 + 5 + 10 = 215

Increasing the deadband (d-b) setting will increase the span between the heating and cooling set points. The range of this adjustment is from -199 - 199°F (-111 - 111°C).

Figure 5.5 Deadband Adjustment

Re-ranging for Linear Process Inputs:

Select the type of input you wish to use from the *inpL* (input type) list in the operators menu on page 11. This would correspond to the output of the sensor or transmitter you are using. If the front display is to read in engineering units instead of temperature and if two decimal places are required, then change the *unit* (display units) setting to *Pu* (process units). In this setting, the "F" and "C" indicators on the control's face will not illuminate. Define the control's range by adjusting the low scale (*Lo.SL*) and high scale (*hi.SL*) setting. Note the following example:

The input type has been set to 4-20mA and the span has been set to read 0-100. At 12mA input, the process

value will read 50. If the input signal goes beyond the range of the low and high limit, an error message (*LLEr* or *HHEr*) will be shown in the upper display. Note the correct input terminals on page 5 to use for the various types of sensors and transmitters.

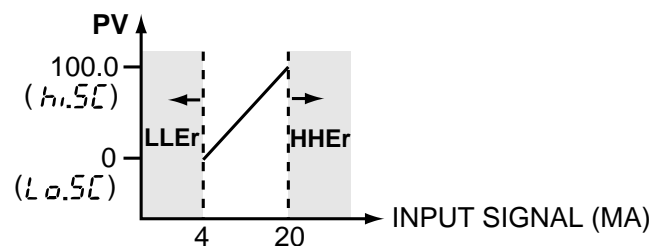

Section 6: CALIBRATION PROCEDURE

WARNING! Do not attempt to recalibrate unless you are absolutely sure that the control needs to be recalibrated and that the proper equipment is available. Once this is preformed, all other calibration information will be lost!

Equipment Needed:

- 1) Standard millivolt power source range 0-100mV, accuracy $\pm 0.01\%$
- 2) Standard voltage power source range 0-10V, accuracy $\pm 0.01\%$
- 3) Standard current power source range 0-20mA, accuracy $\pm 0.01\%$
- 4) Standard ohm source range 0-300 ohm, accuracy $\pm 0.01\%$
- 5) Standard thermometer range 0-50.0°C, accuracy $\pm 0.2^\circ\text{C}$
- 6) A cooling fan may be needed to keep equipment cool
- 7) Thermocouple simulator
- 8) Pushbutton switch

Calibration Set-up:

- 1) Select Input type to J T/C, UNIT = C, RESO = 1dp
- 2) Turn power OFF
- 3) Disconnect all wiring
- 4) Connect wiring as shown below:

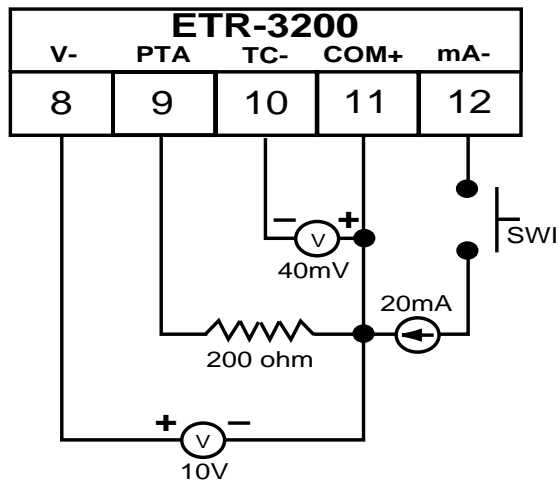

- 5) A fan should be used to keep the cold junction compensator cool. (Lower PCB rear)

Calibration Steps:

- 1) Enter the "Engineering Level" by pressing the and keys simultaneously. Continue to press these keys until is displayed. (See flow chart below.)
- 2) Press the key to view .
- 3) Use the and keys to enter the room temperature on the display in degrees °C. Once the proper room temperature is entered, press the key for 4 seconds. After the key is released, the display will strobe, indicating that the new value has been loaded into the memory.
- 4) Press the key to view .
- 5) The display should read 0.00. Close SW1. The display should now read 20.00. If the value is not 20.00, make sure that the current source is accurate. After a value of 20.00 is displayed in the display, then the key should be pressed for 4 seconds. After the key is released, the display will strobe. This indicates that the new value is properly entered into the controller memory.
- 6) Press the key to view .
- 7) The display should be 0.00. If it isn't, change the value using the and keys. After 0.00 has been obtained, press the key for 4 seconds. When the key is released, the display will strobe. This indicates that the new value has been properly entered into the memory. If the value was 0.00, there is no need to load the information into the memory again.
- 8) Remove all connections. Now connect a thermocouple simulator across terminals 10 and 11 and check calibration (controller must be powered for 30 minutes). If a different input is used, check that input also. If the temperature is incorrect, perform steps (2) and (3) above.
- 9) If the controller is still not accurate the drift must be adjusted. Enter the Engineering Level and go to . Press the key until is displayed. Use the and keys to enter the correction factor that will be shown in the display. This number will be added or subtracted from the display. Once the values are correct, press the key for 4 seconds. This will load the new value into the memory. If the value is successfully entered into the memory, the display will strobe.

ENGINEERING LEVEL

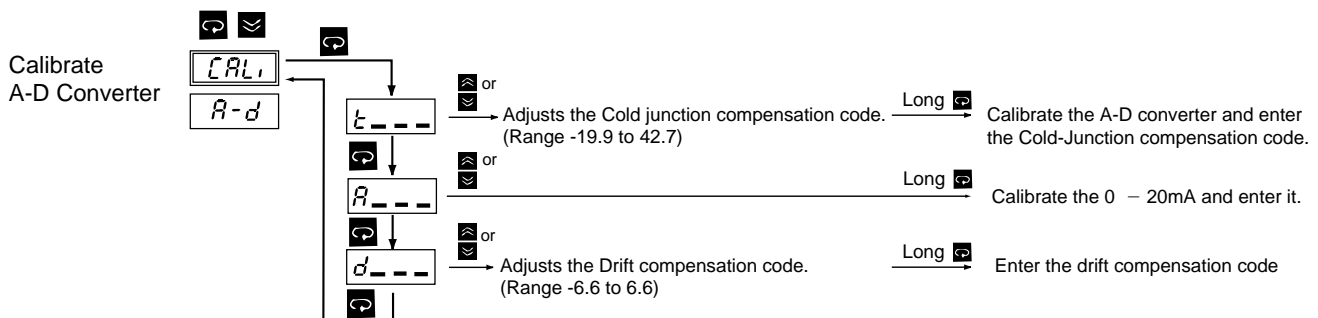

Section 7: TROUBLESHOOTING

WARNING! THIS PROCEDURE REQUIRES ACCESS TO THE CIRCUITRY OF A LIVE POWER UNIT. DANGEROUS ACCIDENTAL CONTACT WITH LINE VOLTAGE IS POSSIBLE. ONLY QUALIFIED PERSONNEL ARE TO PERFORM THESE PROCEDURES. POTENTIALLY LETHAL VOLTAGES ARE PRESENT.

Experience has proven that many control problems are not caused by a defective instrument. See chart below and Table 7.1 on the next page for some of the other common causes of failures:

- | | |
|--|----------------------------------|
| Incorrect parameters entered in menu. | Short across terminals. |
| Excessive electrical interference. | Open or shorted heater circuit. |
| Line wires are improperly connected. | Open coil in external contactor. |
| No voltage between line terminals. | Burned out line fuses. |
| Incorrect voltage between line terminals. | Burned out relay inside control. |
| Connections to terminals are open, missing or loose. | Defective solid-state relays. |
| Thermocouple (or RTD) is open at tip. | Defective line switches. |
| Thermocouple (or RTD) lead is broken. | Burned out contactor. |
| Shorted thermocouple (or RTD) leads. | Defective circuit breakers. |

If the points listed on the chart have been checked and the controller still does not function, it is suggested that the instrument be returned for inspection.

Do not attempt to make repairs. Also, it is advisable to use adequate packing materials to prevent damage in shipment.

Return control to:
OGDEN MANUFACTURING COMPANY
ATTN: REPAIR DEPARTMENT
64 W. SEEGER ROAD
ARLINGTON HEIGHTS, ILL 60005

1) Press latches on each side to remove rear terminal block

2) To remove PCB assembly from housing, insert two small screwdrivers between the PCB and housing top and bottom. This will expand the housing and release the locking tabs. Then pull the PCB assembly out of the housing.



Table 7.1 Troubleshooting Chart

Symptom	Probable Cause(s)	Solution(s)
1.) Keypad not functional.	—PCB assembly not in the housing far enough.	—Recede PCB assembly into the housing.
	—Poor connection between PCB & keypad.	—Clean contact on PCB.
2.) LED's will not light.	—No power to controller.	—Check power line connections.
	—Power supply board.	—Check that power supply board is connected properly.
3.) Some segments of the display or LED's are not lit or are erroneously lit.	—LED's defective.	—Replace LED display or lamp.
	—LED driver defective.	—Replace related transistor or IC chip.
	—Poor connection.	—Check connections.
4.) Process Display shows: <i>SbEr</i>	—Sensor break error.	—Check wiring connection. —Replace RTD or sensor. —Check program for proper input
5.) Process Display shows: <i>LSEr</i>	—Check Sum Error: values in memory may have been changed accidentally.	—Check and reconfigure control parameters.
6.) Process Display shows: <i>LLEr</i>	—Low Limit Error. The process value is below the low limit range.	—Incorrect input type selected. —Replaced sensor. —Readjust <i>LoSL</i>
7.) Process Display shows: <i>HHEr</i>	—High Limit Error. The process value is above the high limit range.	—Incorrect input type selected. —Replace sensor. —Readjust <i>HiSL</i>
8.) Process Display shows: <i>oPEr</i>	—Incorrect operation of autotune.	—Proportion band must be greater than 0. —Repeat Autotune
	—Set point for autotune too low.	—Increase set point.
	—Manual mode not allowable for on-off control.	—Increase proportional band.
9.) Process Display shows: <i>ntEr</i>	—Data failed to be entered into EEPROM	—Replaced EEPROM.
10.) Process Display shows: <i>OvEr</i>	—Overflow Error: Data out of range during execution of software program.	—Check for electrical noise.
11.) Process Display shows: <i>LoLr</i>	—Attempt to change a locked parameter.	—Unlock parameter
12.) Display Unstable.	—Analog portion or A-D converter defective.	—Replace related components or board.
	—Thermocouple, RTD or sensor defective.	—Check thermocouple, RTD or sensor.
	—Intermittent connection of sensor wiring.	—Check sensor wiring connections.
13.) Considerable error in temperature indication.	—Wrong sensor or thermocouple type. Wrong input mode selected.	—Check sensor or thermocouple type and if proper input mode was selected.
	—Analog portion A-D converter defective.	—Replace related components or board.
14.) Display goes in reverse direction (counts down scale as process warms).	—Reversed input wiring of sensor.	—Check and correct.
15.) No heat or output	—No heater power (output), incorrect output device used.	—Check output wiring and output device.
	—Output device defective.	—Replace output device.
	—Open fuse outside of the instrument.	—Replace output fuse.
16.) Heat or output stays on but indicator reads normal.	—Output device shorted, or power service shorted.	—Check and replace.
17.) Control abnormal or operation incorrect.	—CPU or EEPROM (non-volatile memory) defective. Key switch defective.	—Check and replace.
	—Operation of control incorrect.	—Read the operation procedure carefully.
18.) Display blinks, entered values change by themselves.	—Electromagnetic interference (EMI), or Radio Frequency Interface (RFI).	—Suppress arcing contacts in system to eliminate high voltage spike sources. Separate sensor and controller wiring from "dirty" power lines, ground heaters.
	—EEPROM defective.	—Replace EEPROM.