

RF-8000 Series

(Manufactured after 11/92 with Digital Tuning Switch)
Installation & Operation Manual

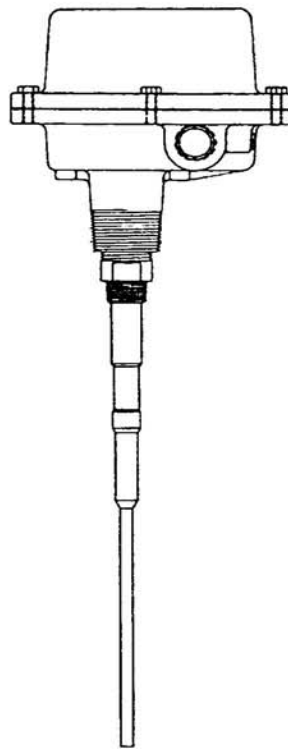

150 Venture Boulevard
Spartanburg, SC 29306
Phone: (864) 574-8060, Fax: (864) 574-8063
Customer Service: (800) 778-9242
Internet: www.bindicator.com
email: sales@bindicator.com

RF 8000 Series

(with DL2 Electronics manufactured after 11/92 with Digital Tuning Switch)

Installation and Operation Manual

<u>Section</u>	<u>Description</u>	<u>Page Number</u>
1.0	INTRODUCTION	1
1.1	Purpose and Use	1
1.2	Operating Theory	1
1.3	Special Features	1
2.0	SPECIFICATIONS	2
2.1	Electronics	2
2.2	Standard Duty Probe	2
2.3	Food Grade Probe with Threaded Connector	2
2.4	Stub Probe	2
2.5	Heavy Duty Probe	3
2.6	Standard Duty - Kynar Coated Probe	3
2.7	Heavy Duty Probe -Kynar Coated	3
2.8	Flush Probe	3
2.9	Enclosure	3
2.10	UL Listed Explosionproof	4
3.0	INSTALLATION	4
3.1	Location and Mounting	4
3.2	Wiring	5
3.3	Fail-Safe Operation	5
3.4	Time Delay Setting	5
3.5	Calibration	7
3.6	Verification	7
4.0	TROUBLESHOOTING	8
4.1	Installation Errors	8
4.2	Application Errors	8
4.2.1	Application Errors	8
4.2.2	High Vibration	8
4.2.3	High Temperature	8
4.2.4	High Corrosive Materials	8
4.2.5	Extremely Light and Dry Materials	8
4.3	Troubleshooting using a Voltmeter	9
4.4	Troubleshooting using a Ohmmeter	9
4.5	Factory Assistance	10
5.0	WARRANTY & PARTS	10
5.1	Warranty	10
5.2	Electronics Replacement	10
6.0	DRAWINGS	10
7.0	MODEL SELECTION	11

Important!

Do not dispose of the carton or packing material until the unit has been inspected for damage.

If the unit is received damaged, notify the carrier or the factory for instructions.

Failure to do so may void your warranty.

Thank you!

1.0 INTRODUCTION

1.1 Purpose and Use

The RF-8000 series are point level controls used to detect the presence or absence material at a point inside a tank, bin or other vessel.

Material coming in contact with the RF-8000 probe causes its output relay to change state; thereby indicating to the user material is present.

The RF-8000 utilizes the PRO-GUARD® principle to prevent false indications from material coating or moisture and condensation on the probe.

1.2 Operating Theory

The RF-8000 are relatively low-powered devices requiring approximately 4 watts for operation. The power supply can accept either 120VAC, 240VAC, 24VDC, or 12VDC (factory selectable) input power. A varistor is used to filter out line transients. A 153.6 KHZ RF oscillator provides the signal which is directed to both the PRO-GUARD® and active sensing area of the probe. (See Figure 1.)

Detection circuitry compares the signal flowing from the active sensing area towards ground (vessel wall) to a reference RF signal. Since all materials have dielectric constants (relative permittivity) and conductance values different from air, the impedance of the signal circuit changes when material touches the probe. This change causes a shift in phase of the RF signal. A phase difference between the active signal and reference signal causes output circuitry to operate.

Sensitivity adjustment determines how much phase shift is needed before the output relay changes state. Time delay selection determines how much time should elapse after detection until the output relay changes state. Fail-safe selection determines whether relay energizes or de-energizes when material is present.

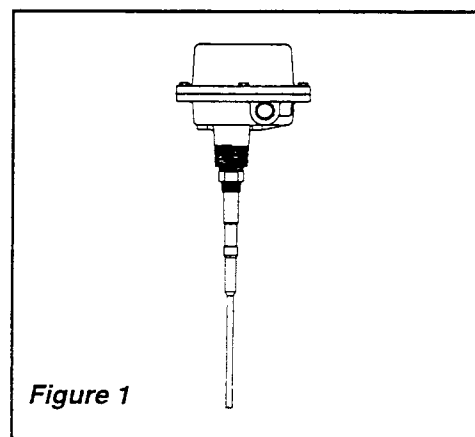

Figure 1

1.3 Special Features

All RF-8000 Series units have solid-state electronics, fail-safe output indication, polyester coated aluminum housing, and PRO-GUARD® probes.

A very important feature of this series is the ability to ignore the effect of coatings that can adhere to the sensing probe. In most applications, a certain amount of the material being sensed will adhere to the sensing probe after a period of time. This can be due to the nature of the material itself or to condensed moisture that can cause dry material to bond to the probe's surface.

Indicator's PRO-GUARD® disregards the effects of probe coating and only indicates that material is present when the actual bulk of material (either dry or liquid) in the bin comes in contact with the probe.

Figure 2 shows the PRO-GUARD® probe. The drive current of PRO-GUARD® electrode is of the same frequency and polarity as that for the probe. When a coating forms on the probe, the RF current from the PRO-GUARD® tends to saturate that portion of the built-up material near the wall so that little or no RF current can flow from the probe to the wall. When the actual bulk material in the bin fills to the point where it is touching the probe, current from the probe will flow around the saturated region and indicate material presence.

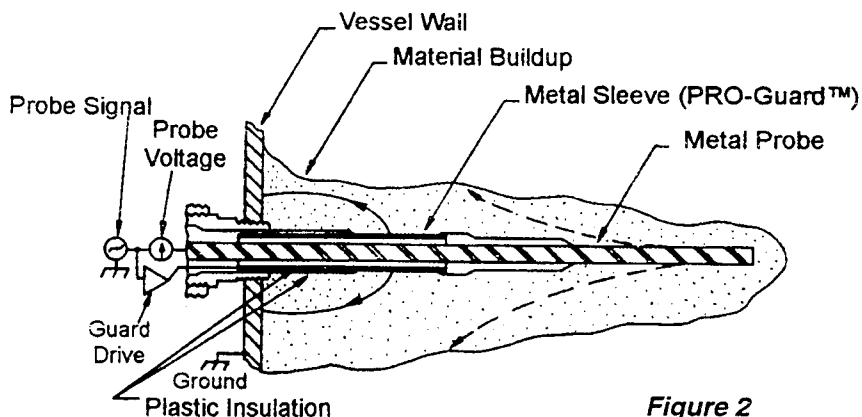

Figure 2

2.0 SPECIFICATIONS

2.1 **Electronics**

Line Voltage: 120VAC \pm 15%, 240VAC \pm 15%, 50/60 Hz,
24VDC \pm 4VDC, 12VDC \pm 4VDC
Power: 4 Watts
Output Relay: DP/DT, 5 amps at 120VAC
Temperature Range: -40° F to +160° F (-40C to +71°C) Medium & Low Sensitivity Setting
-20° F to + 125° F (-20°C to + 50°C) High Sensitivity Setting
Sensitivity Settings: 2 through 11 Picofarad - "0" Electronics
1 through 11 Picofarad - "A" Electronics
Time Delay: 1, 7, 14 Seconds (Selectable)
Calibration: Manual - Field Adjustable

2.2 **Standard Duty Probe**

Dimensions: See Installation Drawing
Mounting: 3/4" NPT - 316 SS or 1 1/4" NPT aluminum
**•• For liquid service use the 3/4" NPT 316 SS thread for proper seal.
1 1/4" NPT aluminum may be used for dry materials.**

Probe Materials: 316 SS and Ryton
Pressure: 150 psi •• (10.5 kgs/cm) (3/4" NPT fitting only)
Probe Temperature: The 316 SS and Ryton probe is rated from -100°F to + 450F
(-73°C to +232°C) *However, it is recommended that application temperatures be limited to +160° F. (71°C) maximum as dictated by the temperature rating of the electronics. If a higher temperature rating is required at the application, please consult factory.*

• Registered trademark of Phillips Chemical Co., Subsidiary of Phillips Petroleum

2.3 **Food Grade (Polysulfone) Probe with Threaded Connector**

Dimensions: See Installation Drawing
Mounting: 3/4" NPT 316 SS or 1-1/4" NPT Aluminum
**••For liquid service use the 3/4"NPT 316 SS thread for proper seal.
1-1/4"NPT aluminum may be used for dry materials.**

Probe Materials: 316 SS and Polysulfone
Pressure: 150 psi•• (10.5 kgs/cm²)
Probe Temperature: -30°F to + 300°F (-34°C to + 149°C) *However, it is recommended that application temperatures be limited to + 160°F (71°C) maximum as dictated by the temperature rating of the electronics. If a higher temperature rating is required at the application, please consult factory.*

2.4 **Stub Probe**

Dimensions: See Installation Drawing
Mounting: 3/4"NPT 316 SS or 1-1/4" aluminum
**••For liquid service use the 3/4"NPT 316 SS thread for proper seal.
1-1/4"NPT aluminum may be used for dry materials.**

Probe Materials: 316 SS and Polysulfone
Pressure: 150 psi•• (10.5 kgs/cm²)
Probe Temperature: -30°F to + 300°F (-34°C to + 149°C)
However, it is recommended that application temperatures be limited to + 160°F (71°C) maximum as dictated by the temperature rating of the electronics. If a higher temperature rating is required at the application, please consult factory.

Consult the factory when using in solid, dry materials where active probe length must be reduced or special configurations are required.

2.5 Heavy Duty Probe

Dimensions: See Installation Drawing
Mounting: 3/4"NPT - 316 SS or 1-1/4"NPT aluminum

****For liquid service use the 3/4"NPT 316 SS thread for proper seal.
1-1/4"NPT aluminum may be used for dry materials.**

Probe Materials: 316 SS and Ryton®*
Pressure: 150 psi** (10.5 kgs/cm²)
Probe Temperature: -100°F to + 450°F (-73°C to + 232°C)
However, it is recommended that application temperatures be limited to + 160°F (71 ° C maximum as dictated by the temperature rating of the electronics. If a higher temperature rating is required at the application, please consult factory.

2.6 Standard Duty - Kynar Coated Probe

Dimensions: See Installation Drawing
Mounting: 3/4"NPT - Teflon Coated
Probe Materials: 316 SS and Ryton Coated with Kynar
Pressure: 50 psi (3.5 kgs/cm)
Probe Temperature: -100°F to + 250°F (-73°C to + 121°C)

However, it is recommended that application temperatures be limited to + 160°F (71°C) maximum as dictated by the temperature rating of the electronics. If a higher temperature rating is required at the application, please consult factory.

2.7 Heavy Duty - Kynar Coated Probe

Dimensions: See Installation Drawing
Mounting: 3/4"NPT - Teflon Coated
Probe Materials: 316 SS and Ryton Coated with Kynar
Pressure: 50 psi (3.5 kgs/cm
Probe Temperature: The 316 SS and Ryton probe is rated from -100°F to + 250°F (-73°C to + 121°C) *However, it is recommended that application temperatures be limited to + 160°F (71°C) maximum as dictated by the temperature rating of the electronics. If a higher temperature rating is required at the application, please consult the factory.*

2.8 Flush Probe

Dimensions: See Installation Drawing
Mounting: See Installation Drawing
Probe Materials: 316 SS and Epoxy
Pressure: 50 psi (3.5 kgs/cm)
Probe Temperature: -30°F to + 200°F (-34°C to + 93°C) Continuous
-30°F to + 250°F (-34°C to + 121°C) Intermittent
However, it is recommended that application temperatures be limited to + 160°F (71°C) maximum as dictated by the temperature rating of the electronics. If a higher temperature rating is required at the application, please consult the factory.

* Registered Trademark of DuPont

** Registered Trademark of Pennwalt

2.9 Enclosure

Dimensions: See Installation Drawing
Material: Aluminum with polyester coating
Ratings: NEMA 4/5, 12 and NEMA 7/9

2.10 UL Listed Explosionproof

Dimensions: See Installation Drawings

Various RF models are available which have been "Listed" as complete assemblies by Underwriters Laboratories for use in Class 1, Div. 1, Groups C & D and Class II, Div 1, Groups E, F, & G atmospheres.

To be listed by UL these units must contain special intrinsic safety barriers to limit the amount of energy on the probe itself in the event of a failure in the electronics. UL also requires a special assembly of the probe to the electronic housing. Because of this special probe seal, the Explosionproof Models are dimensionally different from the General Purpose Units.

The same dimensional difference exists for Coated Standard, Food, Stub, and Coated Heavy Duty probes. No dimensional difference exists in the Flush Probe units.

On explosionproof units, an approved conduit seal fitting must be installed within 18 inches of conduit opening.

CAUTION:

When mounting explosionproof units, never adjust the orientation of the probe or probe housing by turning the housing section. This will break internal wires and permanently damage the probe.

For tightening units with threaded bin connections, the unit must be positioned by using a wrench on the bin connector. Wrench size required is 1-1/16" with open end.

For "Flush Mount" probe units, the position must be adjusted by removing the mounting bolts and moving the entire probe and housing.

3.0 INSTALLATION

3.1 Location and Mounting

The probe should be located out of the direct flow of material while the vessel is being filled. Protective shields or an offset mounting procedure may be required.

Mounting the probe in a nozzle or location where material bridges excessively may cause false indication. The probe should be mounted so material does not build up excessively on the PRO-GUARD® area of the probe. (See **Figure 1.**) If the probe is mounted in a nozzle or nipple, the PRO-GUARD® area must be inside the vessel.

Vertical mounting reduces bridging problems. If material to be sensed is of a nature where buildup will continue to grow on the probe, vertical mounting is necessary.

The RF-8000 unit, when mounted horizontally, should be positioned so the conduit opening is down.

CAUTION:

When mounting explosionproof units, never adjust the orientation of the robe or probe housing by turning the housing section. This will break internal wires and permanently damage the probe.

For tightening units with threaded bin connections, the unit must be positioned by using a wrench on the bin connector. Wrench size required is 1-1/16" with open end. For "Flush Mount" probe units, the position must be adjusted by removing the mounting bolts and moving the entire probe and housing.

3.2 Wiring

Field wiring should conform to the requirements of the National Electrical Code and any other agency or authority having jurisdiction over the installation.

Connect power wiring as per **Figure 3**. For 120VAC units connect hot and neutral on terminals as marked. Ground connection should be made to ground screw located on the lower housing near the conduit entry.

For 240VAC units, connect one hot lead to terminal marked "hot", the other to the terminal marked "Neutral". Connect ground wire to ground screw as mentioned above.

For 24VDC units, connect correct leads to terminals marked "+VDC" and "Common".
For 12VDC units, connect correct leads to terminals marked "+VDC" and "Common".

CAUTION:

Use caution when preparing all wires for connection to the terminal block. Strip insulation a maximum of 1/4 inch or use insulated wire ferrules such as Altech 8969.0 or Altech 2206.0 to prevent shorting of conductors. Tighten screws in terminal block to 4 in/lbs.

3.3 Fail-Safe Selection

The RF-8000 is shipped from the factory in the high level fail-safe condition.

High Level Operation - If the electrical power fails, the relay turns off.
This indicates material as if the tank were full.

Relay Light Logic

Red Relay Light **On** - no material present
Red Relay Light **Off** - material present

Low Level Operation - If the electrical power fails, the relay turns off. This indicates no material as if the tank were empty.

Relay Light Logic

Red Relay Light **On** - material present
Red Relay Light **Off** - no material present

NOTE: For Low Level Fail-safe operating condition, clip the bare wire "fail-safe" selection jumper (See **Figure 3** for location). The Green "Detection LED" is always **off** when material is present, and **on** when no material is present, regardless of fail-safe setting. The relay contact terminals are labeled in the powered, unalarmed state. This status may be opposite that of other brands of level controls. Contacts as marked on the terminals are not the relays nomenclature, but are marked so contacts are in "normal" positions when unit is powered and unalarmed.

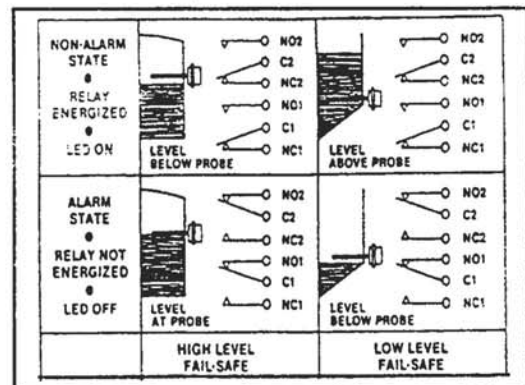

3.4 Time Delay Setting

The RF-8000 units are shipped from the factory in the minimum time delay position. See **Figure 3** for location and position setting. When used in liquid or agitated material where material movement could cause false or premature level indication, an increased time delay selection may be desirable.

Time delays are as follows:

Minimum Setting	1 second
Medium Setting	7 seconds
Maximum Setting	14 seconds

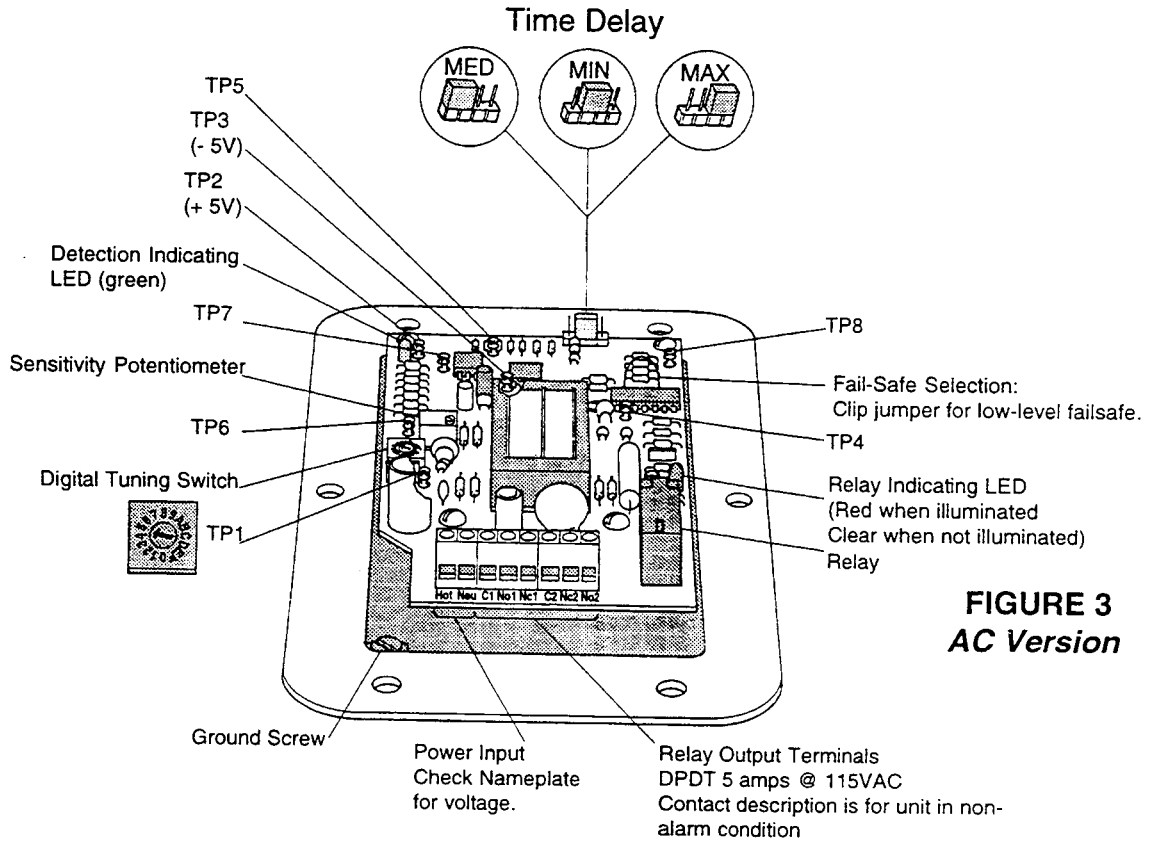

FIGURE 3
AC Version

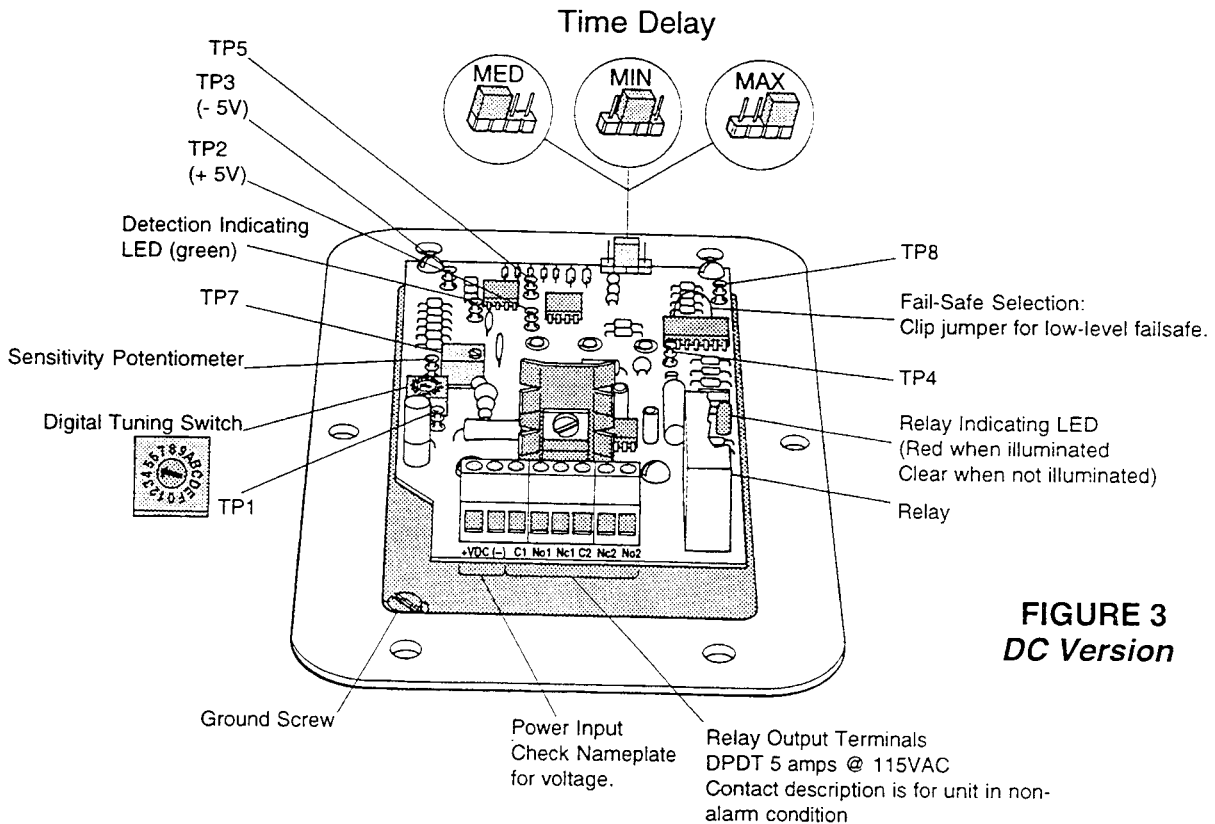

FIGURE 3
DC Version

3.5 Calibration

The RF-8000 units are manufactured with adjustable calibration. Calibration is necessary since all installations are slightly different. Material build up on the probe, significant changes in ambient temperatures, and time may cause a need to Recalibrate a unit.

Preliminary Calibration Steps:

Before recalibrating the unit, the following conditions should exist:

- Unit is installed in vessel and material is well below the probe (3 ft. if possible).
- Equipment that may be started or stopped by the unit is locked out. The relay contacts of the RF unit will open and close during recalibration procedures. Remove the wiring from the relay output terminals if necessary.
- Input power to the unit is present.

Calibration Procedure

1. Turn the "Sensitivity Potentiometer" 32 full turns clockwise (cw). **See Figure 3.**
2. Set the arrow of the Digital Tuning Switch (SW1) to "0" (zero). **See Figure 3.**
3. Turn the "Digital Tuning Switch" clockwise to a higher setting until the green detection indicating LED turns off.
4. Slowly turn the "Sensitivity Potentiometer" counterclockwise (ccw) until the green "Detection Indicating" LED just turns on.
5. Continue turning the "Sensitivity Potentiometer" counterclockwise (ccw) the following number of turns to adjust sensitivity.

One (1) more turn - "Very High (1pf) Sensitivity". Note: For special models only. This setting is for sensing very light, non-conductive materials.

Two and one-half (2-1/2) more turns - "High (2 pf) Sensitivity". This setting is for sensing light, non-conductive materials such as plastic pellets, light powders and dry grain.

Six (6) more turns - "Medium (5 pf) Sensitivity". This setting is for sensing moderately dense or non-conductive liquids such as cement, wet grain and petroleum products.

Fourteen (14) more turns - "Low (11 pf) Sensitivity". This setting is for sensing most aqueous liquid solutions or conductive materials.

3.6 Verification

Raise and lower material level and observe relay indicating LED for verification of proper operating condition. If the unit fails to detect the material, a higher sensitivity setting may be needed. If the unit falsely indicates material presence, a lower sensitivity setting may be needed.

4.0 TROUBLE SHOOTING

4.1 Installation Errors

The probe should be located out of the direct flow of material while the vessel is being filled.

The unit should be mounted with the conduit opening down and located, if possible, higher than the conduit raceway. This will eliminate the possibility of moisture settling in the RF-8000 unit. If conduit is higher than the unit, provide a conduit loop; under the unit with a conduit drain fitting.

Mounting the probe in a nozzle or location where material bridges excessively may cause false indication. The unit should be mounted so material does not build up excessively over the PRO-GUARD® area of the probe. See **Figure 1**. If the unit is mounted in a nozzle or nipple, the PRO-GUARD® area must be inside the vessel.

Vertical mounting reduces bridging problems. If material to be sensed is of a nature where a buildup will continue to grow on the probe, vertical mounting is necessary.

4.2 Application Errors

RF-8000 units have manual calibration and PRO-GUARD® at the probe. They are designed for use in a wide range of free flowing materials. Application considerations for the RF-8000 are as follows:

4.2.1 Extreme Material Buildup

Avoid using it in materials where a continual buildup of a conductive material occurs. The PRO-GUARD® will prevent false indication from material coating and condensation, but a continual, increased buildup will eventually exceed the PRO-GUARD® capability. Because field calibration is a multi-step manual operation, the RF-9000 unit with push-button calibration or the RF9100/9200 series with external calibration capabilities should be applied in this situation.

Selecting a lower sensitivity setting on the RF-8000 may suffice in borderline applications.

4.2.2 High Vibration

Use in vessels and bins with vibrators or other considerable vibration should be avoided unless you are using the "Potted" electronics option. If your application does involve vibration, consider the RF-10000 with remote electronics or the "Potted" electronic option.

4.2.3 High Temperature

The use of the RF-8000 in areas where the housing is subject to ambient temperatures exceeding + 160°F should be avoided. Consider the RF-10000 with remote electronics if your application does involve elevated ambient temperatures.

4.2.4 Highly Corrosive Materials

Wetted probe parts consist of 316 SS and Ryton®. The 1 1/4"NPT mounting connection and enclosure are constructed in aluminum with a polyester coating. If you believe the materials in contact with the probe or mounting may cause corrosion with aluminum, insulation materials, or 316 SS, consult the factory.

4.2.5 Extremely Light and Dry Materials

Use in very light materials (less than 30lbs/cu ft) and very dry, non-conductive materials (less than 3% moisture) should be avoided with the standard RF-8000 unit. Special sensitivity units may be applicable, or the use of the RF-9000 Series units with sensitivity attachments advisable.

Contact our Application Engineers for further guidance.

4.3 RF8000 Electronics Troubleshooting using a Voltmeter

PRELIMINARY

1. Check wiring for proper connections, grounding and voltage.
2. Ensure unit is mounted out of the flow of material.
3. Unit should have been calibrated with material at least 2 feet below the probe.
4. Visually inspect the probe for cracks or abnormalities.

CALIBRATING WITH A VOLTMETER

1. Set the voltmeter to 2 volts DC.
2. Locate TEST POINTS TP6 and TP7 on circuit board (see **Figure 3** in this manual).
3. Connect voltmeter (+) to TP7 and (-) to TP6
4. With the unit calibrated to "HIGH" sensitivity (2-1/2 turns), and the bin empty the voltage should be approximately 0.110 volts.
5. When material contacts the probe, voltage will decrease (negative) until the unit alarms. The voltage will continue to decrease as material covers the probe.

TYPICAL CALIBRATION VALUE

1. The unit calibration should be adjusted so that an alarm condition will cause a decrease in voltage of approximately 50 % in the negative direction.

EXAMPLE:

50% of 0.110 volts = 0.055 volts

Alarm voltage with probe covered should be 0.055 volts in the negative direction, or

Alarm voltage = -0.055 volts

2. If the alarm voltage value does not conform to this percent change, it is likely that the selected calibration value is incorrect. Recalibrate the unit if necessary (see SECTION 4.0 CALIBRATION and SETTINGS in this manual).

4.4 RF8000 Probe Troubleshooting using a Ohmmeter

1. The probe can also be tested using an ohmmeter (continuity).
2. Disconnect the power and remove the electronic circuit board.
3. Test for continuity between all wire combinations (RED-BLUE-GREEN) resistance value should be near infinity or open (general purpose units only).
4. Make sure that all connections of fork terminals to wires are secure, and that local wire connections are correct as follows:

RED = ACTIVE (Probe)
BLUE = (Guard)
GREEN = GROUND (Chassis/Earth)

5. If attempts to locate any difficulties with the unit fail, notify your local representative or BINDICATOR. To help solve your problem quickly, please have as much of the following information as possible:
 - Model number
 - Date purchased
 - Brief application information such as: material to be detected, approximate vessel size and location of unit(s) in the vessel
 - Brief description of the problem such as: fails to detect material or intermittent false alarms.

NOTE: Equipment shipped back to the factory without proper authorization, will be refused and returned at the shipper's expense.

4.5 Factory Assistance

If attempts to locate any difficulties with the unit fail, notify your local representative. To help solve your problem quickly, please have as much of the following information as possible:

- Model Number
- Date purchased
- Brief application information such as: material to be detected, approximate vessel size and location of unit(s) in the vessel.
- Brief description of the problem such as: fails to detect material or intermittent false alarms.

If your local representative is unable to determine the cause of your difficulty, they will refer you to a factory engineer. **Equipment shipped back to the factory without proper authorization, will be refused and returned at the shipper's expense.**

5.0 WARRANTY AND PARTS

5.1 Warranty

Refer to Manufacturer's General Terms and Conditions of Sale for warranty information.

The RF-8000 is designed to give years of unattended service. No scheduled maintenance or parts service is required.

5.2 Electronics Replacement

NOTE: Refer to Figure 4 when replacing electronic circuit board.

CAUTION:

Disconnect input power from its source before attempting to remove the electronic assembly. Follow proper lock-out procedures after turning off the power.

Product Code	Description
LRF110300	120VAC "0" Electronics (2pf)
LRF110301	120VAC "A" Electronics (1pf)
LRF110325	240VAC "0" Electronics (2pf)
LRF110326	240VAC "A" Electronics (1pf)
LRF110363	24VDC "0" Electronics (2pf)
LRF110364	24VDC "A" Electronics (1pf)
LRF110366	12VDC "0" Electronics (2pf)
LRF110392	120VAC "0" Potted (2pf)
LRF110393	240VAC "0" Potted (2pf)
LRF110395	120VAC "A" Potted (1pf)
LRF110602	12VDC "0" Potted (2pf)
LRF110603	24VDC "0" Potted (2pf)

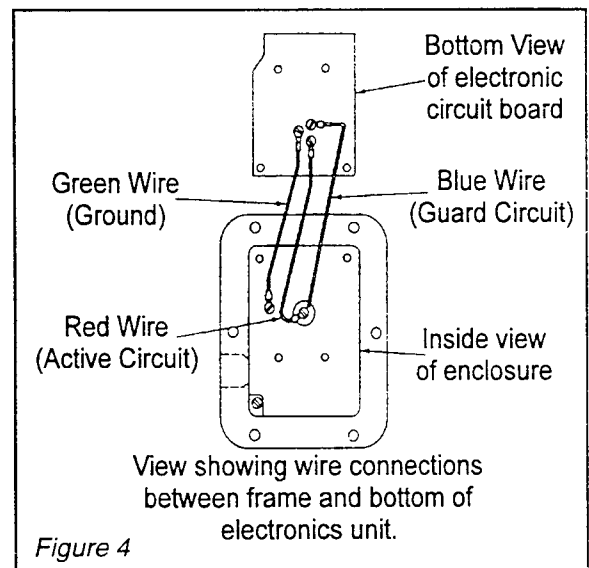

Figure 4

6.0 DRAWINGS

Drawing Number	Description
B-LRF1E0095	RF-8000/9000 Installation & Hook-up Integral Mount - VAC
B-LRF1E0159	RF-8000/9000 Installation & Hook-up Integral Mount - VDC
B-LRF180100	RF-8000/9000 General Purpose with Type "A" Mounting
B-LRF180103	RF-8000/9000 UL/Explosionproof
B-LRF180104	RF-8000/9000 General Purpose with Type "S" Mounting
B-LRF180106	RF-8000/9000 Probe Accessories
B-LRF180113	RF-8000/9000 General Purpose with Type "N" Mounting
B-LRF180114	RF-8000/9000 Stub Probe with Type "A" & "N" Mounting
B-LRF180116	RF-8000/9000 UL Explosionproof with Type "S" Mounting
B-LRF180125	RF-8000 Flush Mount Probe

7.0 MODEL SELECTION

RF-8000 INTEGRAL UNIT

For Product and Application Specifications on the RF-8000, refer to Brochure LRF180019.

Shipping Weight: 9 Lbs.

RF8 - - - - - (See Note 2 Below)

Assembly Configuration

A = 3/4" S.S. & 1 1/4" Aluminum & Flush Mount

S = Sanitary Fitting

N = 1 1/4" Alum. Only (NEMA 4 Only)

(Consult factory for agency listing)

Voltage

1 = 120VAC

2 = 240VAC

3 = 24VDC

4 = 12VDC

5 = 24VAC

6 = 48VAC

Enclosure Type

G = General Purpose NEMA 4/5.

X = Explosionproof NEMA 7/9 - UL Listed (See Note 1 Below)

Probe Type

0 = Standard

1 = Standard, Kynar® Coated.

2 = Food Grade

4 = Stub.

5 = Heavy Duty.

6 = Heavy Duty Kynar® Coated.

8 = Flush (Use "A" Configuration Only).

Electronics

O = Standard (2 pf)

A = Sensitivity Modification (1 pf)

H = Potted Electronics (2 pf).

I = Potted Electronics (1 pf)

RF-8000 Radio Frequency Type Series

Note 1: For use with assembly configurations "A" or "S" only.

Note 2: For **3A Sanitary Certification**, add "3A" at end of the Model Code. Price adder is \$50.00. Configuration "S" must be used and either "Type 2" Food Grade probe or "Type 4" Stub probe.

The probe is rated -100° F. to +450° F., however, it is recommended that application temperatures for the RF-8000 be limited to +160° F. as indicated by the temperature rating of the electronics. If a higher temperature rating is required, please consult the factory.

REV	REVISIONS	DATE	CK'D	APP'D
A	RF7000 HOOKUP DIAGRAM ADDED	FEB 68	SB	SB
B	GRD. WIRE ADDED. NOTE 3	MAR 68	RE	RE
C	TYPE 'N' MOUNTING ADDED TO DWG.	MAY 67	RE	RE

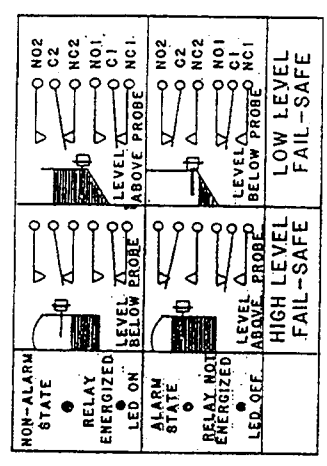
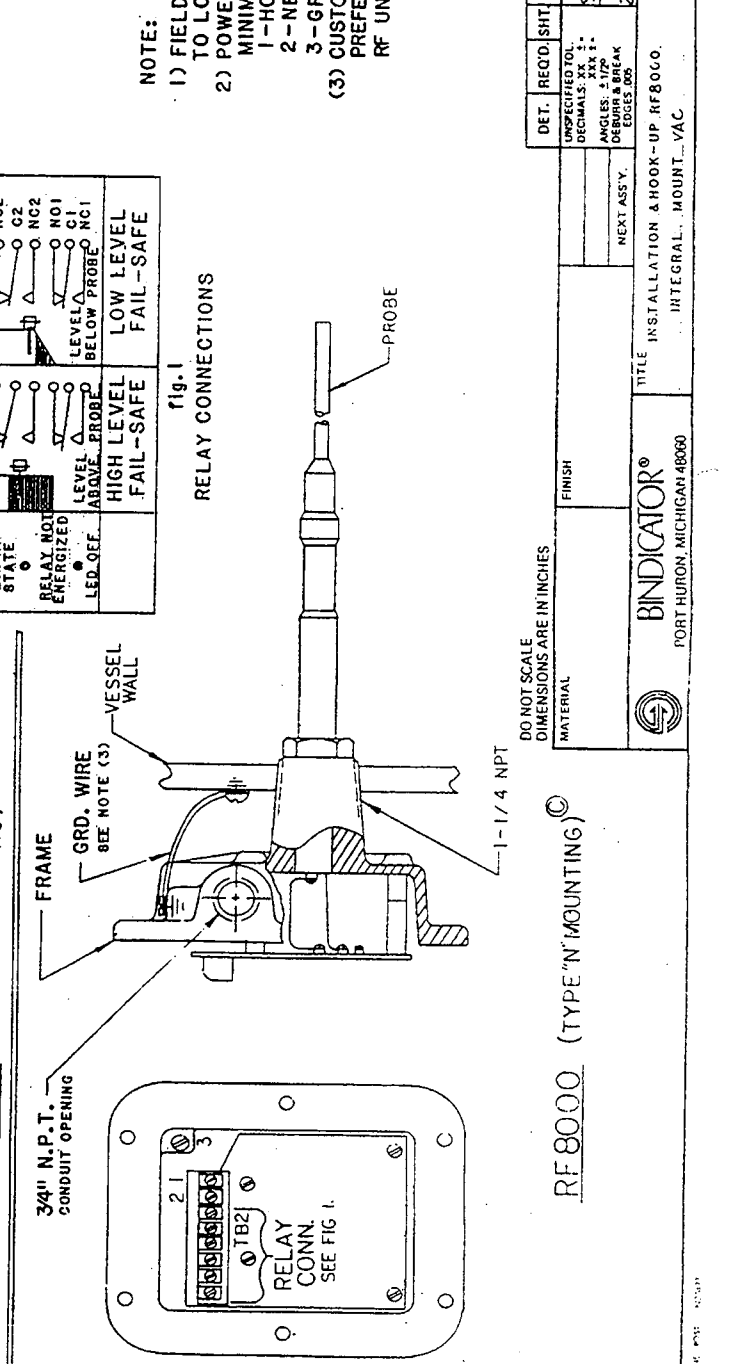
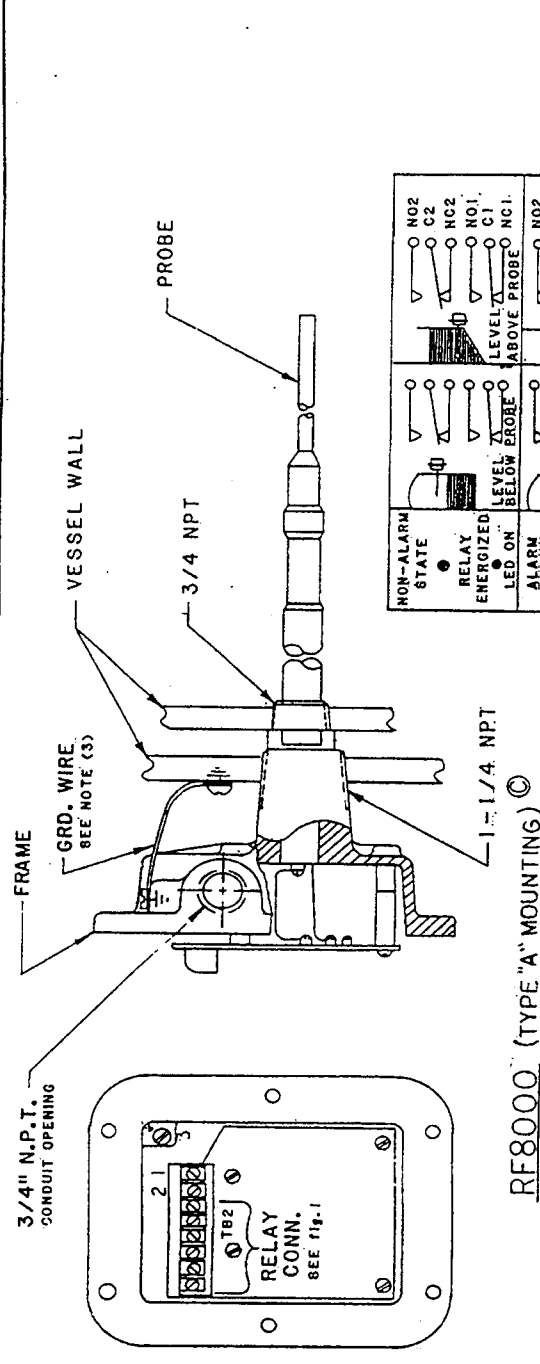

NOTE:
 1) FIELD WIRING SHALL BE ACCORDING TO LOCAL STANDS.
 2) POWER TO UNITS (TB2) 18 AWG MINIMUM RECOMMENDED.
 1-HOT
 2-NEU
 3-GRD TO FRAME SCREW
 CUSTOMER PROVIDED GRD. WIRE.
 PREFERRED METHOD OF GROUNDING RF UNIT TO VESSEL WALL.

DET.	RECD.	SHT	DESCRIPTION	MAT. OR PART
UNSPECIFIED TO DECIMALS: XXX.XX	DRAWN	CHECKED	APPROVED	PROD.
ANGLES: 1/16 DEBURR & BREAK EDGES .005	S. BOEHRM	M. J. L.	RE	RE
DATE	DATE	DATE	DATE	DATE
26 MAY 67	11/10/64	12/11/67	12-27-67	
SCALE	SIZE	PART OR DRAWING	PREVIOUS	
	B	L.R.E.L.E.0095		
TITLE: INSTALLATION & HOOK-UP RF8000. INTEGRAL MOUNT VAC				
MATERIAL: BINDERATOR® PORT HURON, MICHIGAN 48060				

DO NOT SCALE DIMENSIONS ARE IN INCHES

REVISIONS	DATE	CHK'D	APPR'D
-----------	------	-------	--------

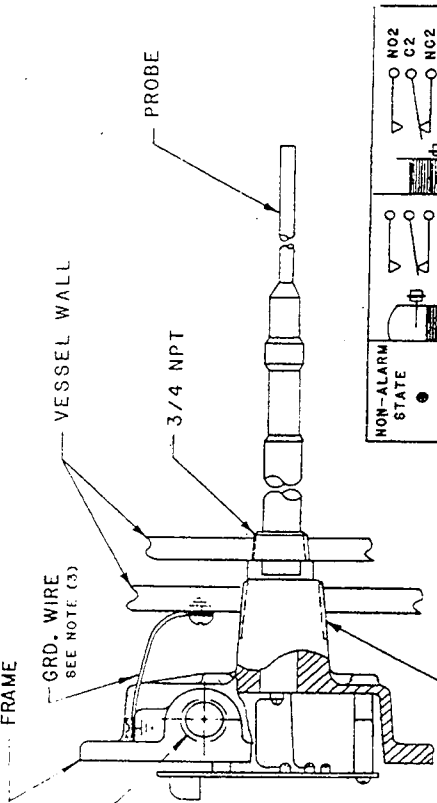

RF8000 (TYPE "A" MOUNTING)

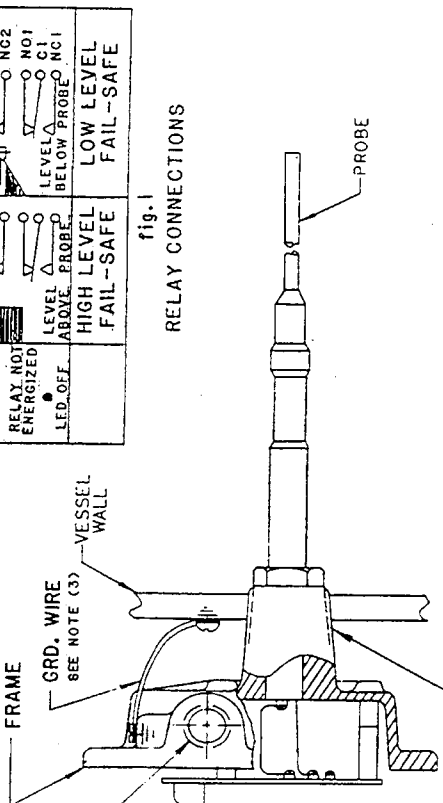

RF8000 (TYPE "N" MOUNTING)

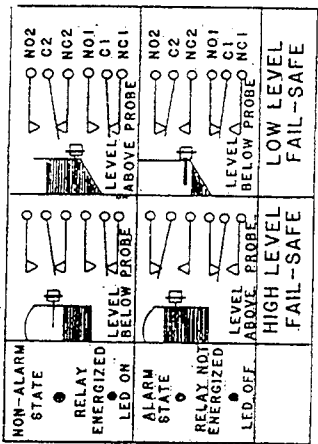

fig. 1
RELAY CONNECTIONS

- NOTE:
- 1) FIELD WIRING SHALL BE ACCORDING TO LOCAL STANDARDS.
 - 2) POWER TO UNITS (TB2) 18 AWG MINIMUM RECOMMENDED.
1-PLUS VDC
2-GRD
 - (3) CUSTOMER PROVIDED GRD. WIRE. PREFERRED METHOD OF GROUNDING RF UNIT TO VESSEL WALL.

DET.	REQ'D.	SHT	DESCRIPTION	MAT. OR PART
INSPECTED TO DECIMALS: XX	DRAWN	CHECKED		
ANGLES & TIPS MARKED FOR EDGES FOR	NEAL	GW		PROJ
	DATE	DATE	DATE	DATE
	12-12-89	12-12-89	12-12-89	12-12-89
	SCALE	SCALE	PART OR DRAWING	PREVIOUS
		B	LRELEO159	
TITLE INSTALLATION & HOOR-UP REF8000. INTEGRAL MOUNT. VDC.				
BINDERATOR® PORT HURON, MICHIGAN 48060				

DO NOT SCALE DIMENSIONS ARE IN INCHES

REVISIONS	
DATE	BY

REDDRAWN ON CAD

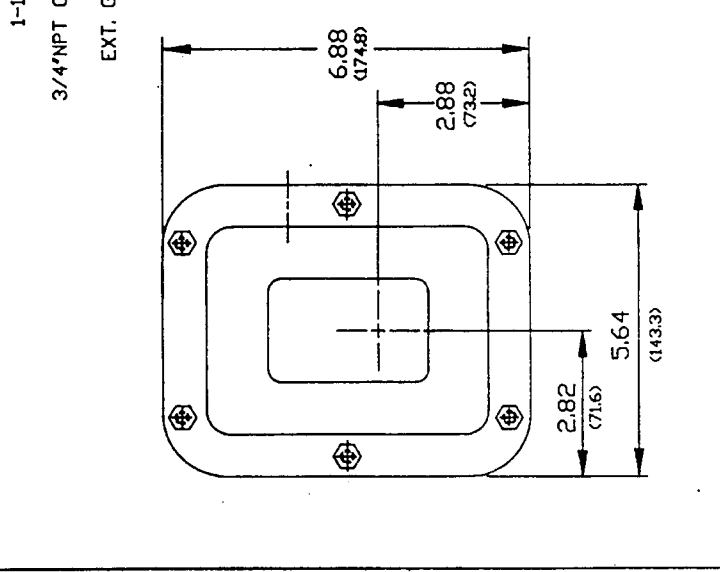
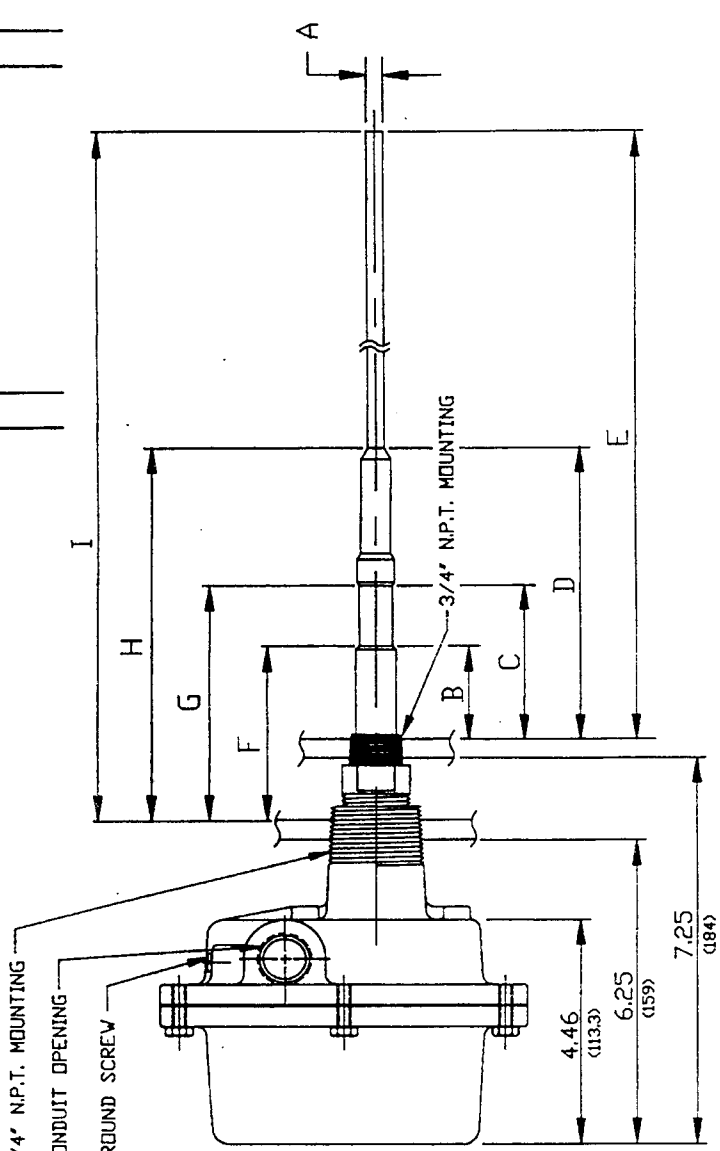

DO NOT SCALE DIM'S. ARE IN INCHES
BRACKETED DIM'S ARE IN MM.

DET. REQUEST	DESCRIPTION	MATERIAL PART
DESIGNED BY: NEAL	CHECKED BY: [Signature]	PROD. [Signature]
DRAWN BY: [Signature]	APPROVED BY: [Signature]	DATE: 11/23/92
DATE: 3/11/91	DATE: 11/23/92	DATE: 11/23/92
SCALE: NONE	SCALE: NONE	SCALE: NONE
SIZE: B	SIZE: B	SIZE: B
TITLE: MANUAL DRAWING RF-8000 & RF-9000 G/P V/TYPE 'A' MOUNTING	TITLE: MANUAL DRAWING RF-8000 & RF-9000 G/P V/TYPE 'A' MOUNTING	TITLE: MANUAL DRAWING RF-8000 & RF-9000 G/P V/TYPE 'A' MOUNTING
PART OR DRAWING: LRF180100	PART OR DRAWING: LRF180100	PART OR DRAWING: LRF180100

APPROX DIM'S	STD. & FOODGRADE	H.D.	STD. KYNAR COATED	H.D. KYNAR COATED
I	15.75 (397.5)	19.25 (489.3)	15.62 (396.1)	19.62 (498.3)
H	7.00 (178)	11.75 (298.3)	7.00 (178)	11.75 (298.3)
G	4.5 (114.3)	10.00 (254)	4.5 (114.3)	10.00 (254)
F	3.38 (86)	8.50 (216)	3.38 (86)	8.50 (216)
E	14.25 (362)	18.25 (463.5)	14.62 (371.4)	18.62 (472.9)
D	6.00 (152.5)	10.75 (273)	6.00 (152.5)	10.75 (273)
C	3.50 (89)	9.00 (228.5)	3.50 (89)	9.00 (228.5)
B	2.38 (60.5)	7.50 (190.5)	2.38 (60.5)	7.50 (190.5)
A	.31 DIA. (8)	.38 DIA. (9.5)	.31 DIA. (8)	.38 DIA. (9.5)

BINDICATOR®
P.O. BOX 1000
MILWAUKEE, WI 53211

REVISIONS		DATE	BY
A	REDRAWN ON CAD SPELLING ERROR, TIGHTENING WAS TIGHTING.	11/23/92	JB

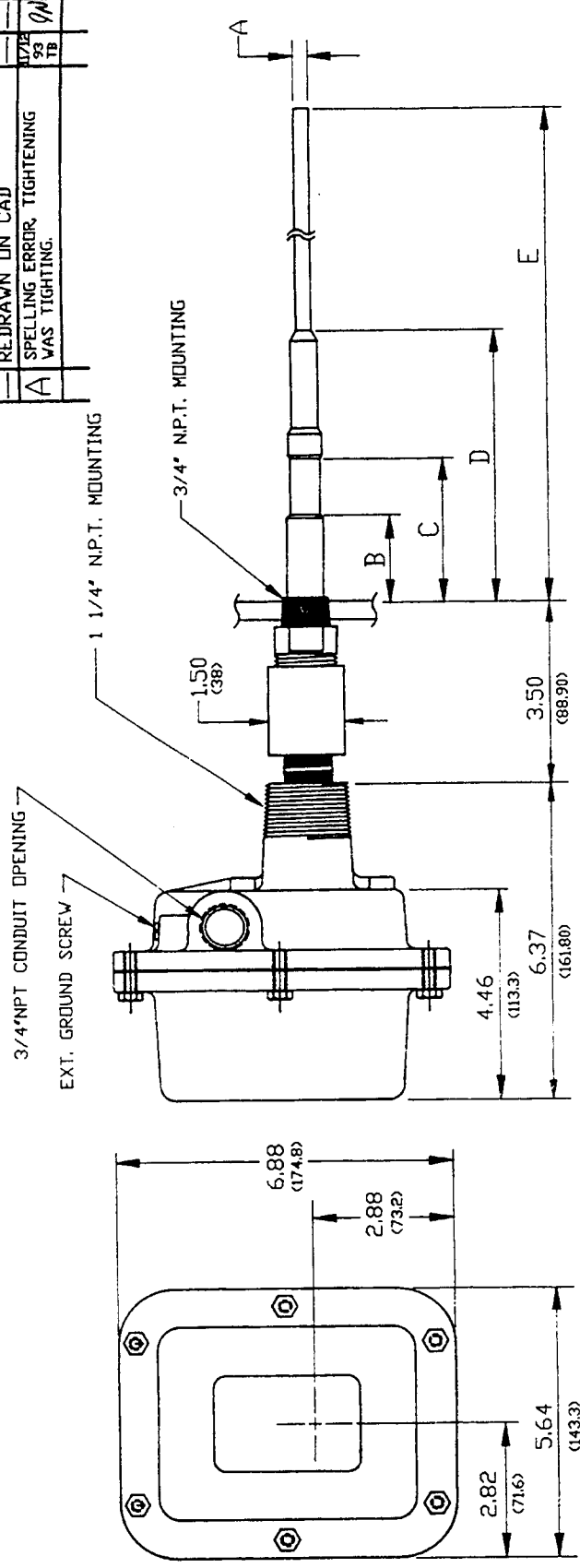

'CAUTION'
 WHEN MOUNTING EXPLOSION PROOF UNITS, NEVER ADJUST THE ORIENTATION OF THE PROBE OR PROBE HOUSING BY TURNING THE HOUSING SECTION. THIS WILL BREAK INTERNAL WIRES AND PERMANENTLY DAMAGE THE PROBE.
 FOR TIGHTENING UNITS WITH THREADED BIN CONNECTIONS, THE UNIT MUST BE POSITIONED BY USING A WRENCH ON THE BIN CONNECTOR. WRENCH SIZE REQUIRED IS 1-1/16 INCH OPEN END.

APPROX DIM'S	14.25 (362)	18.25 (463.5)	14.62 (371.4)	18.62 (472.95)	14.25 (362)
E	14.25 (362)	18.25 (463.5)	14.62 (371.4)	18.62 (472.95)	14.25 (362)
D	6.00 (152.5)	10.75 (273)	6.00 (152.5)	10.75 (273)	2.63 (66.8)
C	3.50 (89)	9.00 (228.5)	3.50 (89)	9.00 (228.5)	2.25 (57.2)
B	2.38 (60.5)	7.50 (190.5)	2.38 (60.5)	7.50 (190.5)	1.75 (44.5)
A	.31 DIA. (.8)	.38 DIA. (.95)	.31 DIA. (.8)	.38 DIA. (.95)	.31 DIA. (.8)
STUB	STD. & FOODGRADE.	H.D.	STD. KYNAR COATED	H.D. KYNAR COATED	STUB

DO NOT SCALE DIM'S. ARE IN INCHES
 BRAK'TED. DIM'S ARE IN MM.

DET. REQ'D	DESCRIPTION	MAT. OR PART
UNDESIGNED TITLE	PROB	
DESIGNED BY	NEAL	
DATE	3/11/91	
DESIGNED BY	RJR	
DATE	11/23/92	
DESIGNED BY	BL	
DATE	11/23/92	
DESIGNED BY	PROB	
DATE	11/23/92	
SCALE	NONE	
PART OR DRAWING	B	LRF180103

BINDICATOR®
 PORT HURON, MICHIGAN 48060

TITLE MANUAL DRAWING
 RF8000 & RF9000 UL X/P

REVISIONS		DATE	BY
A	REDRAWN ON CAD SPELLING ERROR, VESSEL WALL WAS VESEL WALL.	11/23/92	RB

13MMHM CAST CLAMP SIZE 1-1/2 CHERRY-BURRELL 'S' OR LADISH TRI-CLAMP. (CUSTOMER SUPPLIED)
1.990 O.D. (50.55)
3/4" NPT CONDUIT OPENING EXT. GROUND SCREW
VESSEL WALL
L114M7 BUTT WELDING FERRULE SIZE 1 X .870 I.D. CHERRY BURRELL 'S' OR LADISH TRI CLAMP. (CUSTOMER SUPPLIED)
40 MP-G TEFLON GASKET SIZE 1 X .875 I.D. CHERRY BURRELL 'S' OR LADISH TRI-CLAMP. (CUSTOMER SUPPLIED)
S.S. BIN CONNECTOR

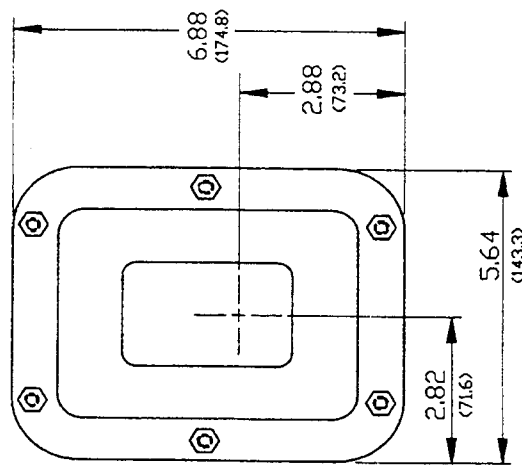
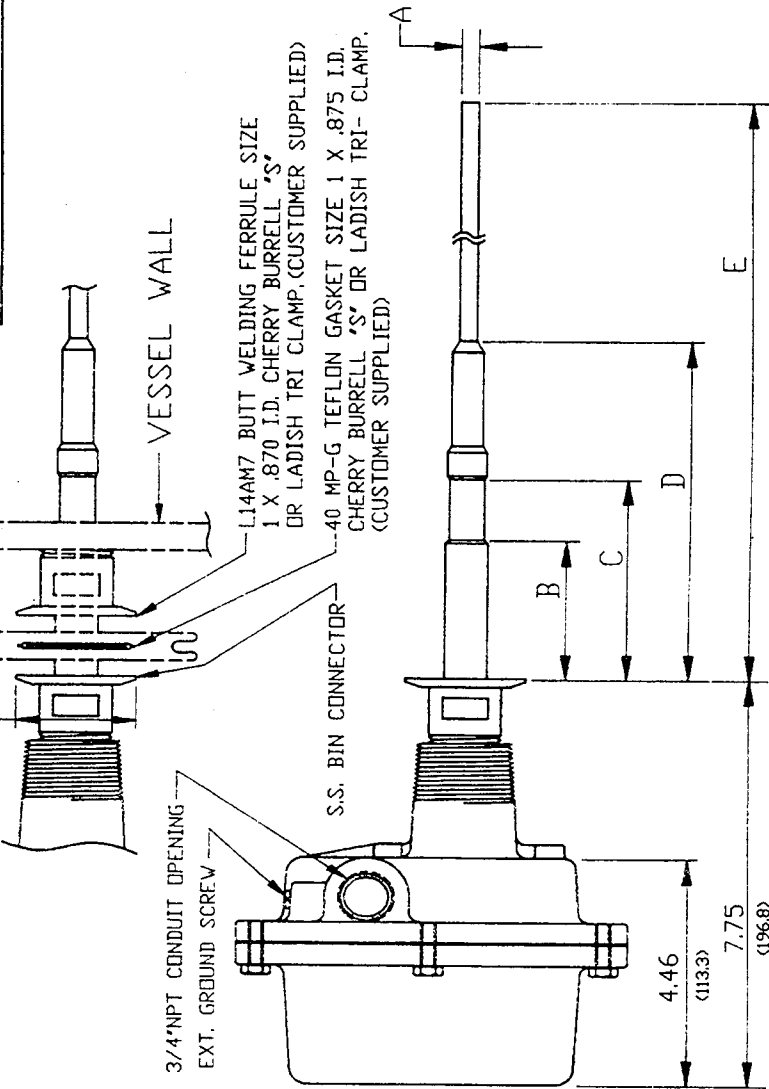

APPROX DIM'S	FOODGRADE	STUB
E	14.25 (362)	14.25 (362)
D	6.00 (152.4)	2.75 (69.9)
C	3.62 (91.95)	2.00 (50.8)
B	2.38 (61.5)	1.50 (38)
A	.31 DIA. (8)	.31 DIA. (8)

DO NOT SCALE DIM'S. ARE IN INCHES
BRAK'TED; DIM'S ARE IN MM.

DET. REQ'D SHIT	DESCRIPTION	MAT. OR PART
UNAPPROVED TOL. DRAWN BY: NEAL	CHECKED BY: RJR	APPROVED BY: RB
TECHNICAL DOK #	DATE: 11/23/92	DATE: 11/23/92
ANNO UNDES. & BREAK	SCALE: NONE	PART OR DRAWING: B
ENGRS. JMS	SIZE: NONE	PART OR DRAWING: LRF180104
TITLE: MANUAL DRAWING RF8000 & RF9000 G/P V/TYPE 'S' MOUNTING		
MATERIAL: FINISH		
MATERIAL: BINDICATOR®		
PDRT HURONMICHIGAN 48060		

REVISIONS		REVISIONS		DATE	CK'D	APP'D
A	EXT. GRD. ADDED				RL	RL
B	SPELLING ERROR, INCREMENTS			11/17/88		AN
C	ADDED PROB. SET SCR.			11/17/88		AN

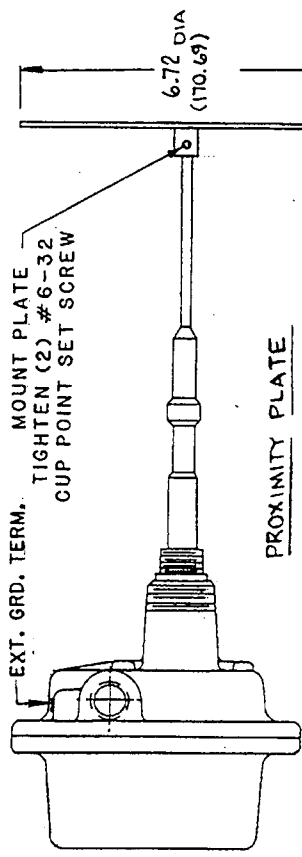

DESCRIPTION	A DIM.	B DIM.
3/4 MOUNT STD PROBE	.75 (19)	8.31 (211)
1/4 MOUNT STD PROBE	1.375 (34.92)	8.31 (211)
3/4 MOUNT H.D. PROBE	.75 (19)	7.56 (192)
1/4 MOUNT H.D. PROBE	1.375 (34.92)	7.56 (192)

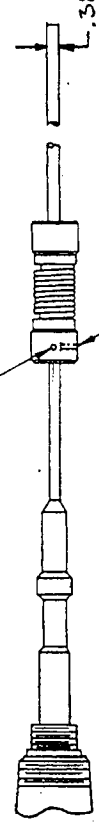
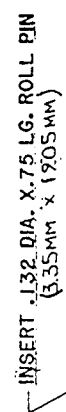

FLEXIBLE EXTENSION
AVAILABLE FROM 1 FOOT TO 5 FEET
LONG IN 1 FOOT INCREMENTS.

RIGID EXTENSION
AVAILABLE FROM 1 FOOT TO 5 FEET
LONG IN 1 FOOT INCREMENTS.

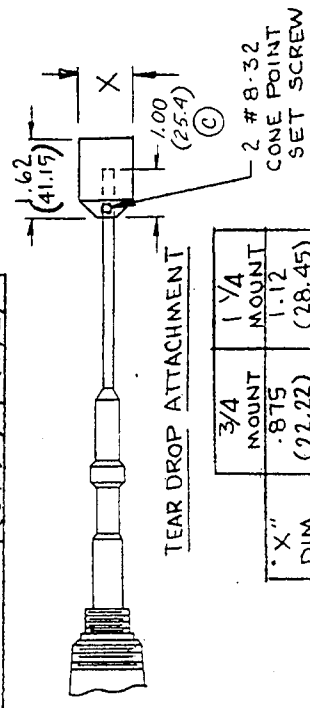

* X" DIM.	3/4 MOUNT	1/4 MOUNT
	.875 (22.22)	1.12 (28.45)

DO NOT SCALE DIMENSIONS ARE IN INCHES

DET.	RECD.	SHT.	DESCRIPTION	MAT. OR PART
UNSPECIFIED TOL.	APPROVED	PROJ.		
DECIMALS: XX I.	BY	NO.		
ANGLES: XX X I.	RANDY			
DECURR & BREAK	DATE	DATE		
EDGES .005	12-12-88	12-12-88		
NEXT ASSY.	SCALE	PART OR DRAWING		
	NONE	B	LR180106	
TITLE		PREVIOUS		
MANUAL DRAWING				
PROBE ACCESSORIES				

MATERIAL

FINISH

BINDICATOR®
PORT HURON, MICHIGAN 48860

REVISIONS	
DATE	BY

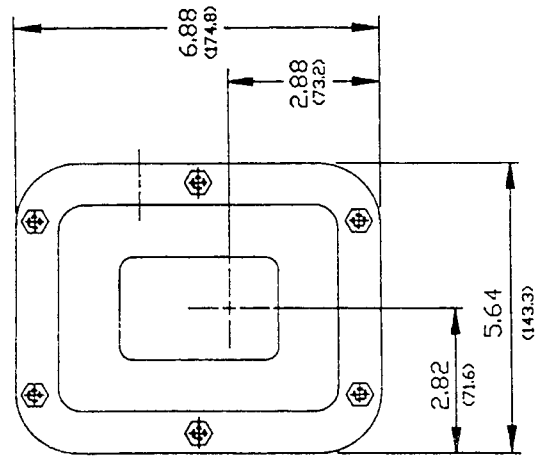
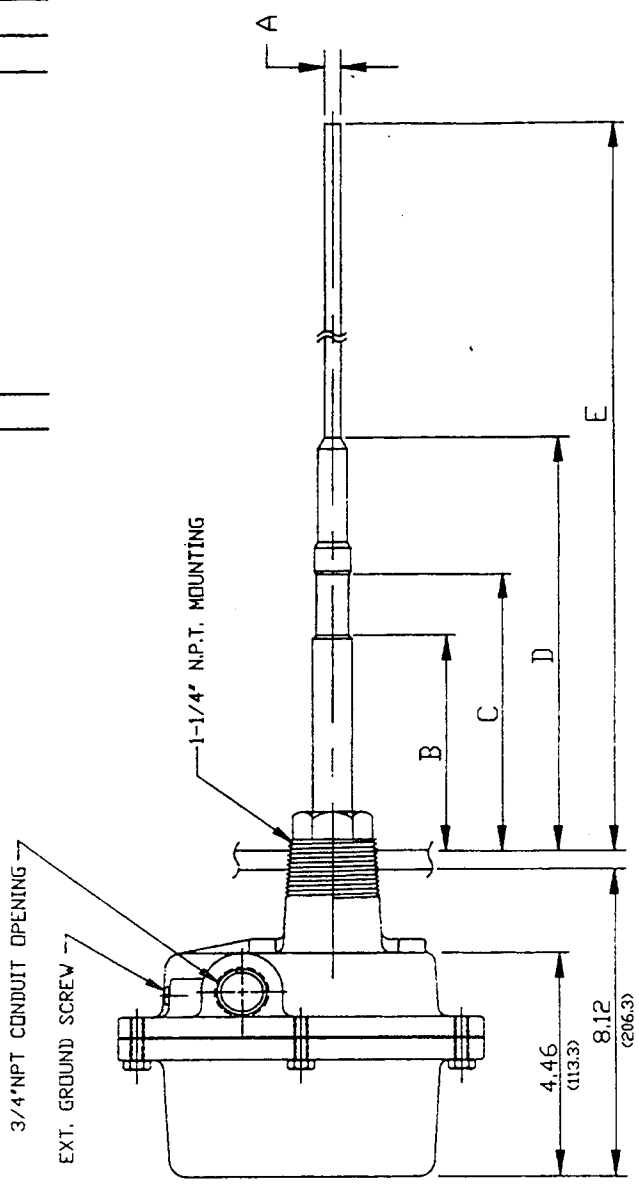

APPROX DIM'S	STD. & FOODGRADE	H.D.	STD. KYNAR COATED	H.D. KYNAR COATED	.31 DIA. (.8)	.38 DIA. (9.5)	3.38 (86)	8.5 (216)	3.38 (86)	.85 (21.6)	10.00 (254)	4.50 (114.3)	7.00 (178)	11.75 (298.5)	19.25 (489)	15.62 (396.7)	19.62 (498.35)
E																	
D																	
C																	
B																	
A																	

DO NOT SCALE DIM'S. ARE IN INCHES
BRACKETED DIM'S ARE IN MM.

DESIGNER	DATE	APPROVED	DATE	SCALE	NON	DESCRIPTION	MATERIAL
NEAL	3/11/91	BL	11/23/92	B	RF8000 & RF9000 G/P V/TYP 'N' MOUNTING	RF8000 & RF9000 G/P V/TYP 'N' MOUNTING	RF8000 & RF9000 G/P V/TYP 'N' MOUNTING
MATERIAL		FINISH		TITLE		PART OR DRAWING	
BINDERATOR®		PORT HURON, MICHIGAN 48060		RF8000 G/P V/TYP 'N' MOUNTING		B LRF180113	

REVISIONS

DATE	CHKD	APPD

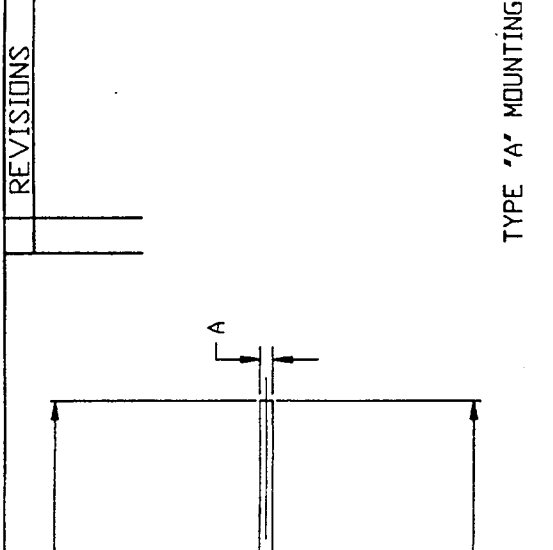

TYPE 'A' MOUNTING

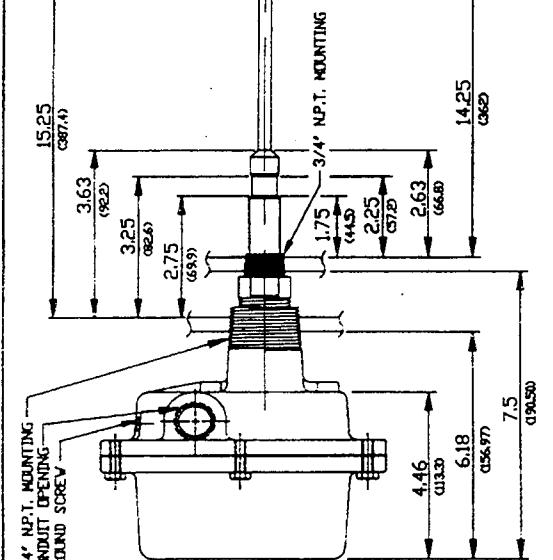

TYPE 'N' MOUNTING

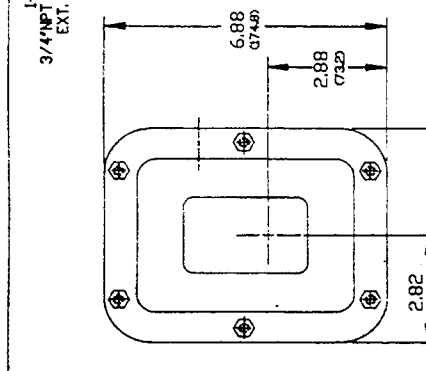
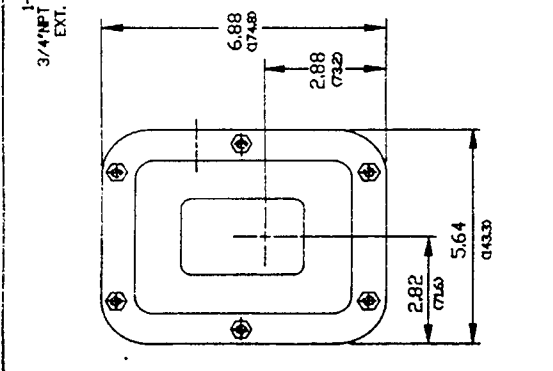

DET. REQUISIT		DESCRIPTION		MAJOR PART	
DESIGNED BY	NEAL	CHECKED	BL	APPROVED	BL
DATE	3/11/91	DATE	1/23/92	DATE	1/23/92
SCALE	NONE	SCALE	NONE	SCALE	NONE
FINISH		SCALE	B	SCALE	B
MATERIAL		PART OR DRAWING		PART OR DRAWING	
BINDER		LRF180114		LRF180114	

TITLE
 MANUAL DRAWING RF8000 & RF9000 G/P
 STUB PROBE V/TYPE 'A' & 'N' MOUNTING

DO NOT SCALE DIM'S. ARE IN INCHES
 BRAK'TED. DIM'S ARE IN MM.

REVISIONS		DATE	BY
A	SPELLING ERROR, TURNING WAS TURNING.	11/23/92	MB

13MMH CAST CLAMP SIZE 1-1/2 CHERRY BURRELL 'S' DR LADISH TRI-CLAMP. *

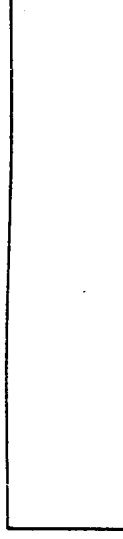

DET.	REQD	TH	DESCR	MAT.	PART
UNSPECIFIED	THE	FINISH			
REVISIONS	DATE	BY			
APPROVED	DATE	BY			
CHECKED	DATE	BY			
DESIGNED	DATE	BY			
DRAWN	DATE	BY			
SCALE	SCALE	SCALE			
SIZE	SIZE	SIZE			
PART OR DRAWING	PART OR DRAWING	PART OR DRAWING			

10.25 (260.35)

4.46 (113.3)

6.88 (174.8)

2.82 (71.6)

5.64 (143.3)

2.88 (73.2)

4.46 (113.3)

10.25 (260.35)

6.88 (174.8)

2.82 (71.6)

5.64 (143.3)

2.88 (73.2)

4.46 (113.3)

10.25 (260.35)

6.88 (174.8)

2.82 (71.6)

5.64 (143.3)

2.88 (73.2)

4.46 (113.3)

10.25 (260.35)

6.88 (174.8)

2.82 (71.6)

5.64 (143.3)

2.88 (73.2)

4.46 (113.3)

10.25 (260.35)

6.88 (174.8)

2.82 (71.6)

5.64 (143.3)

2.88 (73.2)

4.46 (113.3)

10.25 (260.35)

6.88 (174.8)

2.82 (71.6)

5.64 (143.3)

2.88 (73.2)

4.46 (113.3)

10.25 (260.35)

6.88 (174.8)

2.82 (71.6)

5.64 (143.3)

2.88 (73.2)

4.46 (113.3)

10.25 (260.35)

6.88 (174.8)

2.82 (71.6)

5.64 (143.3)

2.88 (73.2)

4.46 (113.3)

10.25 (260.35)

6.88 (174.8)

2.82 (71.6)

5.64 (143.3)

2.88 (73.2)

4.46 (113.3)

10.25 (260.35)

6.88 (174.8)

2.82 (71.6)

5.64 (143.3)

2.88 (73.2)

'CAUTION'
WHEN MOUNTING EXPLOSION PROOF UNITS, NEVER ADJUST THE ORIENTATION OF THE PROBE OR PROBE HOUSING BY TURNING THE HOUSING SECTION. THIS WILL BREAK INTERNAL WIRES AND PERMANENTLY DAMAGE THE PROBE.
FOR TIGHTENING UNITS WITH THREADED BIN CONNECTIONS, THE UNIT MUST BE POSITIONED BY USING A WRENCH ON THE BIN CONNECTOR. WRENCH SIZE REQUIRED IS 1-1/16 INCH OPEN END.

*CUSTOMER SUPPLIED

E	14.25 (362)	14.38 (362)	STUB
D	6.00 (152.5)	2.75 (69.9)	
C	3.62 (91.95)	2.00 (50.8)	
B	2.38 (60.5)	1.50 (38.1)	
A	.31 DIA. (8)	.31 DIA. (8)	

DO NOT SCALE DIM'S. ARE IN INCHES
BRACKETED DIM'S ARE IN MM.



BINDERATOR®
PORT HURON/MICHIGAN 48060

TITLE MANUAL DRAWING RF8000 & RF9000 UL X/P W/TYPE 'S' MOUNTING

SCALE NONE

SIZE B

PART OR DRAWING LRF180116

DESCRIPTION

MATERIAL FINISH

UNSPECIFIED	THE	FINISH	
REVISIONS	DATE	BY	
APPROVED	DATE	BY	
CHECKED	DATE	BY	
DESIGNED	DATE	BY	
DRAWN	DATE	BY	
SCALE	SCALE	SCALE	
SIZE	SIZE	SIZE	
PART OR DRAWING	PART OR DRAWING	PART OR DRAWING	

REVISIONS	DATE	BY	APP'D
-----------	------	----	-------

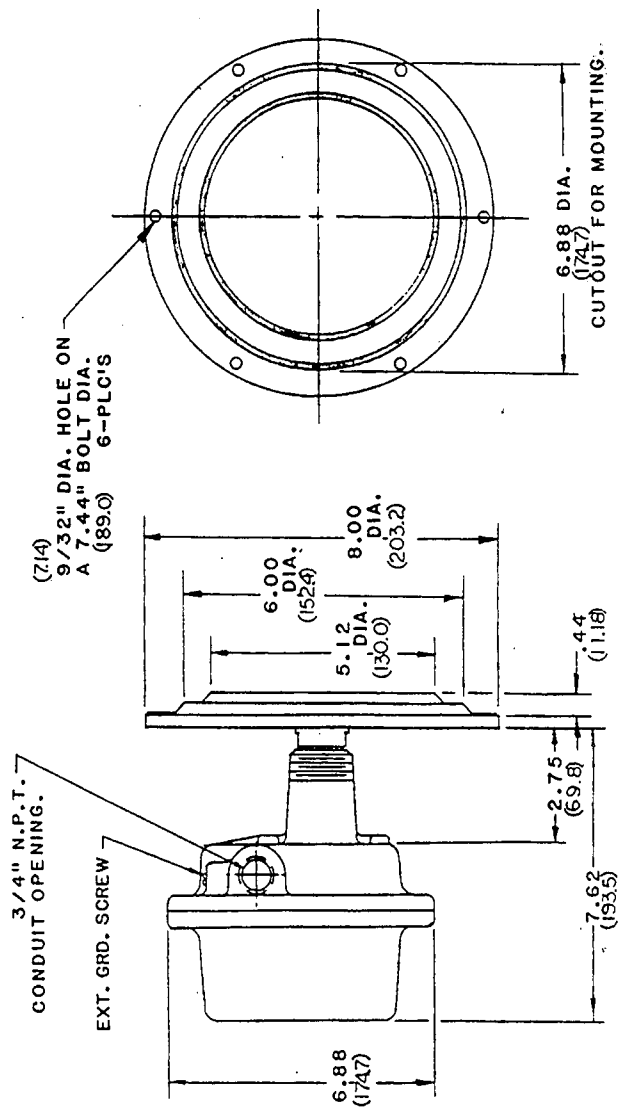

CAUTION
 WHEN MOUNTING EXPLOSION PROOF UNITS, NEVER ADJUST THE ORIENTATION OF THE PROBE OR PROBE HOUSING BY TURNING THE HOUSING SECTION. THIS WILL BREAK INTERNAL WIRES AND PERMANENTLY DAMAGE THE PROBE.
 FOR 'FLUSH PROBE' UNITS THE POSITION MUST BE ADJUSTED BY REMOVING THE MOUNTING BOLTS AND MOVING THE ENTIRE PROBE & HOUSING.

- Mounting Surface Preparations
- Lay out two concentric circles on bin wall at point where the RF Level Control is to be mounted. One circle to be 6-7/8" diameter; the other 7-7/16" diameter.
 - Cut out 6-7/8" diameter circle.
 - Lay out six equally spaced holes on 7-7/16" diameter circle. Drill or tap for 1/4" bolts or cap screws.

DO NOT SCALE DIMENSIONS ARE IN INCHES		DRAWN BY: J. J. M. J.'S		MATERIAL:		FINISH:		TITLE: MANUAL DRAWING FLUSH PROBE	
DET.	RECT.	SHT.	DESCRIPTION	MAT.	OR PART	INSPECTED TO:	APPROVED:	DATE:	DATE:
						DECIMALS: 1/16"			
						ANGLES: 1/2"			
						DEBURR & BREAK EDGES: 0.05			
						NEXT ASSY.			
						SCALE: NONE			
						PART OR DRAWING: LRF180125			
						PREVIOUS:			

INDICATOR®
 PORT HURON, MICHIGAN 48050

REF.

GENERAL TERMS AND CONDITIONS OF SALE

1. PAYMENT Terms of payment are Net 30 days and are effective from the actual date of invoice. If, in the Seller's opinion, the financial condition of the Buyer at any time-or any other circumstances do not justify the incurrence of production costs or shipment on the terms of payment specified, the Seller may require partial or full payment in advance.

2. F.O.B. All shipments are F.O.B. Seller's factory in Port Huron, Michigan, unless otherwise stated in the quotation.

3. QUOTATION AND PRICES Quoted prices are firm for thirty days and are subject to change without notice after expiration of this period. Orders calling for future deliveries will be invoiced according to prices in effect at the time of shipment.

4. TAXES Any applicable sales, use, revenue, excise or other taxes not specifically stated in the quotation are to be remitted by the Buyer directly to the appropriate regulatory agency.

5. EQUIPMENT WARRANTY/LIMITATION The following BINDICATOR products are warranted for a period of two years from date of shipment against defective materials and workmanship: RF Series, Mark III Yo-Yo, General Purpose Yo-Yo, Micro-Sonic Series, Eagle, Mach One, Leveldata, Tracker, and Levelite Series. All CELTEK and other Bindicator products are warranted for a period of one year from date of shipment against defective materials and workmanship. WE MAKE NO OTHER WARRANTY, EXPRESS OR IMPLIED, AND ANY WARRANTY OF MERCHANTABILITY OR FITNESS FOR A PARTICULAR PURPOSE WHICH EXCEEDS THE FOREGOING IS HEREBY DISCLAIMED AND EXCLUDED FROM THIS CONTRACT. If the products are being acquired for resale, Buyer will make, in connection with any such resale, only those warranties contained herein and will indemnify us against any claims, causes of actions and judgements which arise from any representations, warranties or agreements made by or entered into by Buyer, other than those contained herein.

6. BUYER'S EXCLUSIVE REMEDY In the event of any breach of warranty, the sole and exclusive remedy of Buyer (or any person claiming through Buyer) shall be limited to the repair or replacement of defective products or parts, at our plant or at Seller's option, to the refund of the purchase price, provided that notice of such defects is given within six months after shipment. In no event will our liability include any incidental or consequential damages.

7. DELIVERY The Seller shall not be liable for loss or damage of any kind resulting from delay or inability to deliver or account of flood, fire, strike, labor troubles, riot, civil disturbances, accidents, acts or orders or regulations of civil or military authorities, shortages of materials, or any other cause or causes (whether or not similar in nature to any of these enumerated) beyond Seller's control.

8. PRODUCT CHANGES In keeping with our continuing policy of product improvement, we reserve the right to make changes in our products at any time, without incurring an obligation to change equipment previously shipped.

9. RETURN OF GOODS In no case may products or parts be returned without Seller's prior written permission. Products or parts returned under the aforementioned Equipment Guarantee must be shipped with transportation charges prepaid. All other returns must be shipped with transportation charges prepaid and will be subject to a restocking charge. Only products of standard Bindicator manufacture will be accepted for return. Products which are specially modified or produced to the Buyer's specifications will not be accepted for return.

10. CONTRACT FORMATION A binding contract shall not be effective until a written purchase order is received at Seller's office in Port Huron, Michigan and accepted in writing by an authorized employee of the Seller at its Port Huron office. The terms and conditions in our quotation or acknowledgment shall govern the contract and any different or additional terms in Buyer's purchase order, unless approved by Seller in writing, are hereby objected to.

11. CONSTRUCTION Any agreement arrived at shall be considered to be a Michigan contract and shall be construed under the laws of the State of Michigan.

12. CANCELLATION Request for cancellation must be in writing and referred to Bindicator. No orders will be accepted with the understanding that they may later be cancelled. If and when cancellation is approved by Bindicator, it is with the understanding that Bindicator will be fully reimbursed by payment of cancellation charge: which are to be determined by Bindicator.

13. CERTIFICATION OF NONSEGREGATED FACILITIES Our firm does not maintain facilities of a segregated nature contrary to the provision of 41 CFR 60-1.8, and further that if we have 50 or more employees and our contractual arrangements of \$50,000 or more we have complied with 41 CFR 60-1.7 concerning the annual filing of a report on Standard Form 100 (EEO-1) and with 41 CFR 60-1.40 by developing a written Affirmative Action Compliance Program.



150 Venture Boulevard
Spartanburg, SC 29306
Phone: (864) 574-8060, Fax: (864) 574-8063
Customer Service: (800) 778-9242
Internet: www.bindicator.com
Email: sales@bindicator.com