



**INTERNATIONAL HEADQUARTERS**  
 20 Willow Springs Circle, York, Pa. 17402, (717) 767-6511 FAX: (717) 764-0839  
 Web site- <http://www.redlion-controls.com> E-mail- [sales@redlion-controls.com](mailto:sales@redlion-controls.com)

**EUROPEAN HEADQUARTERS**  
 892 Plymouth Road, Slough, Berkshire SL1 4LP  
 ENGLAND +44 1753 696888 FAX: +44 1753 696339

## DITAK 7 - ADJUSTABLE TIMEBASE 5-DIGIT RATE INDICATOR

- LCD, POSITIVE REFLECTIVE OR NEGATIVE TRANSMISSIVE WITH YELLOW/GREEN OR RED BACKLIGHTING
- 0.6 INCH (15.2mm) HIGH DIGITS
- ADJUSTABLE TIMEBASE FROM 4 MSEC TO 32 SEC
- SELECTABLE DECIMAL POINTS
- REPLACEABLE LITHIUM BATTERY PROVIDES UP TO 5 YEARS OF CONTINUOUS OPERATION (Battery included)
- NEMA 4X/IP65 SEALED FRONT PANEL BEZEL
- ACCEPTS MAGNETIC OR LOGIC TYPE SIGNAL INPUTS
- WIRE CONNECTIONS MADE VIA SCREW CLAMP TYPE TERMINALS

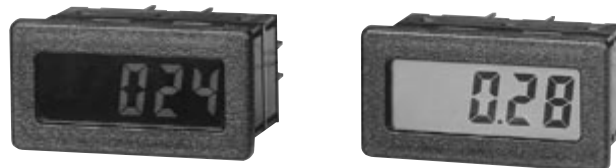

### DESCRIPTION

The Ditak 7 is a self-powered rate indicator which features selectable Timebase Increments by setting the appropriate DIP switches on the rear of the unit. The internal plug-in 3.0 VDC lithium battery, requires NO soldering, making it easily replaceable in the field. It has a 5-digit LCD display with 0.6 inch (15.2 mm) high digits and a DIP switch selectable decimal point. The displays are available in positive image reflective (black digits, reflective background) or negative image transmissive (illuminated digits, dark background) with red or yellow/green backlighting. Backlight version units require power from an external 9 to 28 VDC supply.

Like other Micro-Line products, the Ditak 7 combines the use of a custom CMOS LSI counter chip and custom timebase gate array. These chips are mounted on a gold-plated substrate and electrically connected by ultrasonic wire-bonding. Internal electrical interface connections use elastomeric contacts to provide a gas-tight, corrosion resistant connection. Use of the latest in Micro-Electronic assembly and manufacturing techniques provides units with reliability and dependability required for industrial applications.

The unit is constructed of a lightweight, high impact plastic case with a clear viewing window. The sealed front panel meets NEMA 4X/IP65 specifications for wash-down and/or dusty environments, when properly installed. A Ditak 7 unit can be mounted in the same panel cut-out as the earlier Ditak 5 & 6 series units.

The optional Micro Line/Sensor Power Supply (MLPS0000) is designed to attach to the rear of an installed Ditak 7. The optional supply can be powered from either a 115 or 230 VAC source, and can provide power for the backlighting of a unit and a sensor.

### SAFETY SUMMARY

All safety related regulations, local codes and instructions that appear in the manual or on equipment must be observed to ensure personal safety and to prevent damage to either the instrument or equipment connected to it. If equipment is used in a manner not specified by the manufacturer, the protection provided by the equipment may be impaired.

### SPECIFICATIONS

- DISPLAY:** 5-Digit LCD, 0.6" (15.2 mm) high digits.
- POWER SOURCE:** Internal 3.0 V lithium battery provides up to 5 years of continuous service (battery life is dependent upon usage). For replacement procedure, refer to battery installation figure. The Ditak 7 can also receive power at Terminal 3 (INP) from a logic or magnetic signal with a minimum peak voltage of 4.0 V, which will serve to extend the battery life. Must use the MLPS or a Class 2 or SELV rated power supply.
- BACKLIGHT POWER REQUIREMENTS:** 9 to 28 VDC @ 35 mA. Above 26 VDC, derate operating temperature to 50°C.
- SIGNAL INPUT:** 0 to 10 KHz from a magnetic or bi-polar output (with a 50% duty cycle). Min. input sensitivity is 0.9 V. Max. input = 28 VDC.
- TIMEBASE:** Adjustable in 1/256 sec (3.906 msec) increments via DIP switches located at the rear of the unit. Timebase ranges from 3.906 msec to 31.996 sec; 0.05% accuracy.
- ENVIRONMENTAL CONDITIONS:**
  - Operating Temperature:** 0 to 60°C (Above 50°C derate backlight operating voltage to 26 VDC max.)
  - Storage Temperature:** -40 to 80°C
  - Operating and Storage Humidity:** 85% max. (non-condensing) from 0°C to 60°C.
  - Altitude:** Up to 2000 meters
- CONSTRUCTION:** High impact plastic case with clear viewing window (Panel gasket and mounting clip included). Installation Category I, Pollution Degree 2.

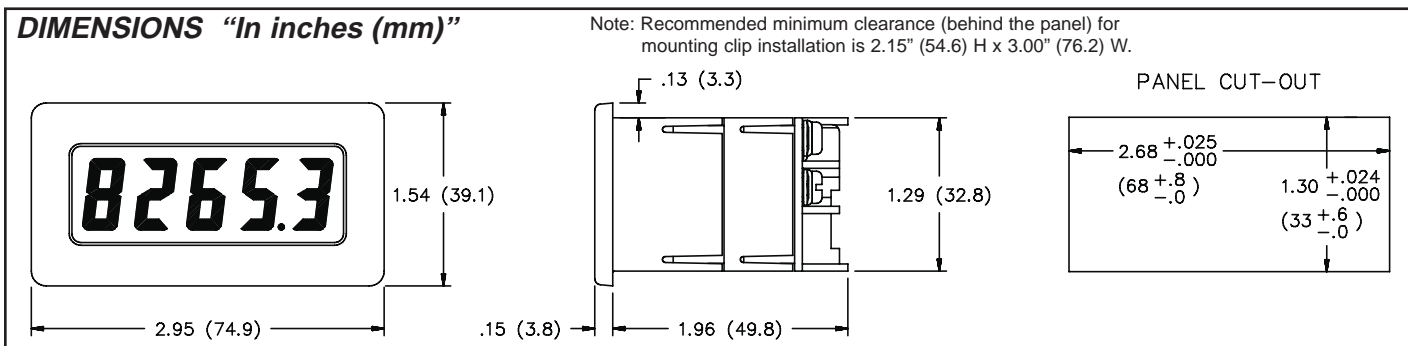
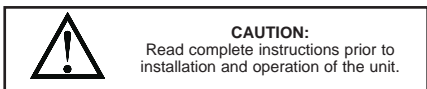

## SPECIFICATIONS (Cont'd)

### 8. CERTIFICATIONS AND COMPLIANCES:

#### EMC EMISSIONS:

Meets EN 50081-1: Residential, Commercial, and Light Industry  
CISPR 11 Radiated and conducted emissions

#### EMC IMMUNITY:

Meets EN 50082-2: Industrial Environment.  
ENV 50140 - Radio-frequency radiated electromagnetic field  
ENV 50141 - Radio-frequency conducted electromagnetic field<sup>1 & 2</sup>  
EN 61000-4-2 - Electrostatic discharge (ESD)  
EN 61000-4-4 - Electrical fast transient/burst (EFT)  
EN 61000-4-8 - Power frequency magnetic field

#### Notes:

##### 1. RF Conducted Immunity I/O lines

Cable shield connected to earth ground at both ends.

##### 2. RF Conducted Power lines

At 10 V rms, from 24 to 65 MHz, rate display value varies.

a. At 8 V rms unit operates normally.

b. At 10 V rms, use of a line filter (LFIL0000) or one ferrite suppression core on power lines enables normal unit operation.

Refer to the EMC Installation Guidelines section of this bulletin for additional information.

### 9. WEIGHT: 3.3 oz (93.5 g)

## EMC INSTALLATION GUIDELINES

Although this unit is designed with a high degree of immunity to ElectroMagnetic Interference (EMI), proper installation and wiring methods must be followed to ensure compatibility in each application. The type of the electrical noise, source or coupling method into the unit may be different for various installations. In extremely high EMI environments, additional measures may be needed. Cable length, routing and shield termination are very important and can mean the difference between a successful or a troublesome installation. Listed below are some EMC guidelines for successful installation in an industrial environment.

1. Use shielded (screened) cables for all Signal and Control inputs. The shield (screen) pigtail connection should be made as short as possible. The connection point for the shield depends somewhat upon the application. Listed below are the recommended methods of connecting the shield, in order of their effectiveness.

a. Connect the shield only at the panel where the unit is mounted to earth ground (protective earth).

b. Connect the shield to earth ground at both ends of the cable, usually when the noise source frequency is above 1 MHz.

c. Connect the shield to common of the unit and leave the other end of the shield unconnected and insulated from earth ground.

2. Never run Signal or Control cables in the same conduit or raceway with AC power lines, conductors feeding motors, solenoids, SCR controls, and heaters, etc. The cables should be run in metal conduit that is properly grounded. This is especially useful in applications where cable runs are long and portable two-way radios are used in close proximity or if the installation is near a commercial radio transmitter.

3. Signal or Control cables within an enclosure should be routed as far away as possible from contactors, control relays, transformers, and other noisy components.

4. In extremely high EMI environments, the use of external EMI suppression devices, such as ferrite suppression cores, is effective. Install them on Signal and Control cables as close to the unit as possible. Loop the cable through the core several times or use multiple cores on each cable for additional protection. Install line filters on the power input cable to the unit to suppress power line interference. Install them near the power entry point of the enclosure. The following EMI suppression devices (or equivalent) are recommended:

Ferrite Suppression Cores for signal and control cables:

Fair-Rite # 0443167251 (RLC #FCOR0000)

TDK # ZCAT3035-1330A

Steward #28B2029-0A0

Line Filters for input power cables:

Schaffner # FN610-1/07 (RLC #LFIL0000)

Schaffner # FN670-1.8/07

Corcom #1VR3

**Note:** Reference manufacturer's instructions when installing a line filter.

5. Long cable runs are more susceptible to EMI pickup than short cable runs. Therefore, keep cable runs as short as possible.

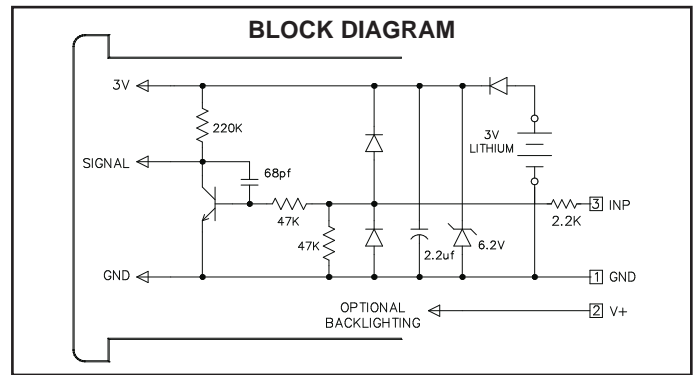

## WIRING CONNECTIONS

The electrical connections are made via rear screw-clamp terminals located on the back of the unit. All conductors should meet voltage and current ratings for each terminal. Also cabling should conform to appropriate standards of good installation, local codes and regulations. It is recommended that power supplied to the unit (AC or DC) be protected by a fuse or circuit breaker. When wiring the unit, use the label to identify the wire position with the proper function. Strip the wire, leaving approximately 1/4" bare wire exposed (stranded wires should be tinned with solder). Insert the wire into the screw-clamp terminal and tighten the screw until the wire is clamped tightly. Each terminal can accept up to two #14 AWG wires.

The backlighting for a backlight version unit is powered between Terminal 2 (V+) and Terminal 1 (GND).

## REAR PANEL DIP SWITCHES

When viewing the Ditak 7 from the rear, there are two banks of DIP switches, with eight switches per bank, located along the top edge of the PC board. The bank to the left is labeled SWA and the bank to the right is labeled SWB. All of the SWA switches and five of the SWB switches are used to select the desired Timebase. The remaining switches of SWB are used to select Frequency Doubling and the Decimal Point position.

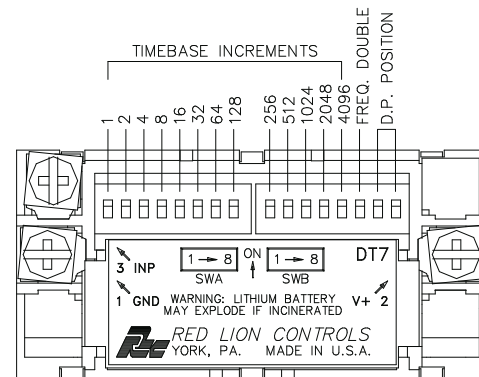

**Note:** The model DT700000 will NOT have a screw terminal installed at Terminal 2 (V+), since it is NOT required for operation, and is not internally connected. The DT700M00 uses the V+ screw terminal to mount the MLPS power supply. It is not internally connected to the unit.

**WARNING:** Lithium battery may explode if incinerated.

## TIMEBASE SELECTION

The Ditak 7 has a Timebase selection range from 4 msec to 32 sec. SWA 1 is set to the "ON" position for the minimum Timebase setting. SWA 1 through SWB 5 are set to the "ON" position for the maximum Timebase setting. A specific Timebase setting is achieved by adding the appropriate individual Timebase increments. The Timebase increment total is computed according to the following formula:

$$\text{TIMEBASE INCREMENT TOTAL (TBIT)} = \frac{\text{DR} \times \text{DDP} \times 15,360}{\text{RPM} \times \text{PPR}}$$

### WHERE:

DR = Desired Reading  
 DDP = Display Decimal Point  
 RPM = Revolutions Per Minute  
 PPR = Pulses Per Revolution

**DDP:** Use one of the following numbers in the above formula for the display decimal point (DDP) position.

0 = 1  
 0.0 = 10  
 0.00 = 100

SWITCH	TIMEBASE INCREMENTS	SWITCH	TIMEBASE INCREMENTS
SWA 1	1	SWB 1	256
SWA 2	2	SWB 2	512
SWA 3	4	SWB 3	1024
SWA 4	8	SWB 4	2048
SWA 5	16	SWB 5	4096
SWA 6	32		
SWA 7	64		
SWA 8	128		

**Example:** Find the appropriate Timebase DIP switch setting for a desired display decimal point position of 0.0 reading with a fixed shaft speed.

$$\text{TIMEBASE INCREMENT TOTAL (TBIT)} = \frac{\text{DR} \times \text{DDP} \times 15,360}{\text{RPM} \times \text{PPR}}$$

Desired Readout (DR) = 250.0  
 Revolutions Per Minute (RPM) = 1250  
 Pulses Per Revolution (PPR) = 50

$$\text{TBIT} = \frac{250.0 \times 10 \times 15,360}{1250 \times 50} = \frac{38,400,000}{62,500} = 614.4$$

TBIT = 614 {round to the nearest whole number}

TBIT = 614

DIP SWB 2	-	<u>512</u>	-	Needed
DIP SWA 7	-	<u>64</u>	-	Needed
DIP SWA 6	-	<u>32</u>	-	Needed
DIP SWA 3	-	<u>4</u>	-	Needed
DIP SWA 2	-	<u>2</u>	-	Needed
		0	-	Needed

DIP switches SWA 2, 3, 6, 7, and SWB 2 are all set to the "ON" position for a Timebase Increment Total of 614. If it is desired to know what the approximate Timebase is in seconds, use the following formula:

$$\begin{aligned} \text{TBIT} \times 0.004 &= \text{Time in seconds} \\ 614 \times 0.004 &= 2.456 \text{ sec.} \end{aligned}$$

## FREQUENCY DOUBLING

DIP switch SWB 6 is the "Frequency Doubling" switch. When it is in the "ON" position, frequency doubling is disabled. When set to the "OFF" position, it is enabled and twice the number of input pulses are registered in the unit. This doubling of the input rate allows the Timebase Increment Total to be halved, thus allowing a faster update time for a given display value.

$$\begin{array}{l} \text{SWB 6 ON} \\ \text{FRQ. DBL. DIS. (X1)} \end{array} \qquad \begin{array}{l} \text{SWB 6 OFF} \\ \text{FRQ. DBL. (X2)} \end{array}$$

## BATTERY INSTALLATION

- To remove battery cover, unsnap at either of the lower rear corners and pull cover straight out (refer to drawing below).
- Remove the plug-in battery and replace with an RLC battery (BNL00000). Observe proper polarity when replacing battery as shown in the drawing.
- Allow 32 seconds for the first update to occur after battery is replaced.

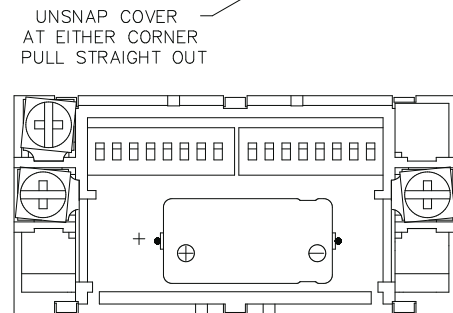
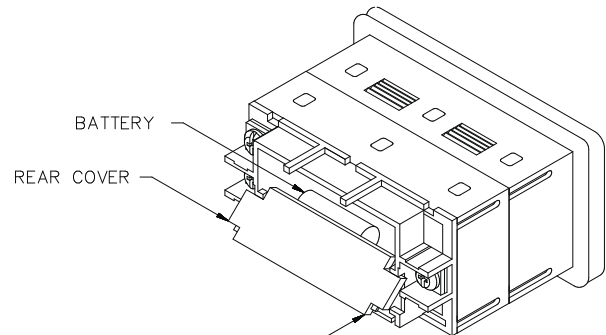

## DECIMAL POINT SELECTION

The selection of Decimal Point is accomplished by DIP switches SWB 7 and SWB 8. The table shows what combinations of switches are needed to obtain the desired decimal point location. The Ditak 7 always has leading zero blanking.

SWB 7	SWB 8	D.P. LOCATION
ON	ON	Factory test mode
ON	OFF	0
OFF	ON	0.0
OFF	OFF	0.00

Note: The Decimal Point position will take effect when the display updates.

## TROUBLESHOOTING

For further technical assistance, contact technical support at the appropriate company numbers listed.

## INSTALLATION ENVIRONMENT

The unit should be installed in a location that does not exceed the maximum operating temperature and provides good air circulation. Placing the unit near devices that generate excessive heat should be avoided.

The bezel should be cleaned only with a soft cloth and neutral soap product. Do NOT use solvents.

Continuous exposure to direct sunlight may accelerate the aging process of the bezel.

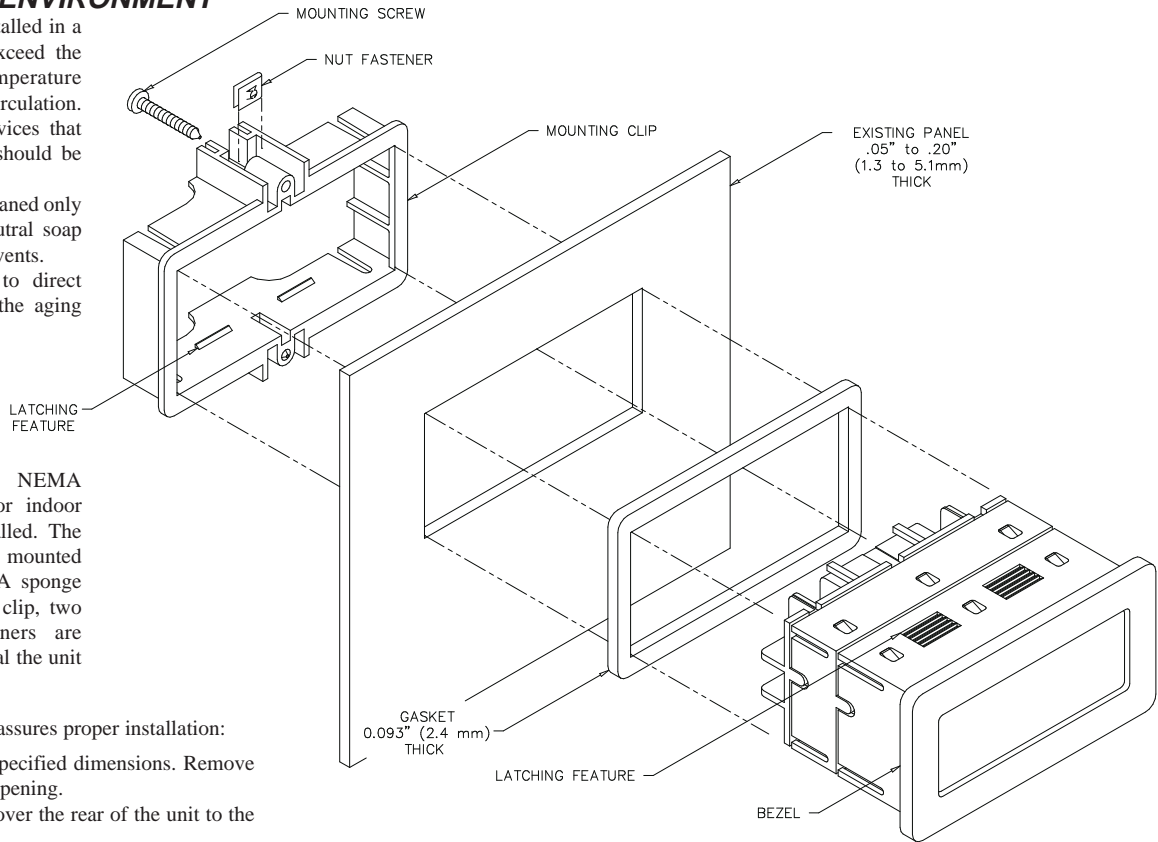

## INSTALLATION

The Ditak 7 meets NEMA 4X/IP65 requirements for indoor use, when properly installed. The units are intended to be mounted into an enclosed panel. A sponge rubber gasket, mounting clip, two screws, and nut fasteners are provided to install and seal the unit in the panel cut-out.

The following procedure assures proper installation:

1. Cut panel opening to specified dimensions. Remove burrs and clean panel opening.
2. Slide the panel gasket over the rear of the unit to the back of the bezel.
3. Slide nut fastener into slot on mounting clip and then insert mounting screw through nut on both sides of mounting clip. Tip of mounting screw should NOT project through hole on clip.
4. Install Ditak unit through panel cut-out.
5. Slide mounting clip over rear of unit until clip is against back of panel. The mounting clip and Ditak housing have a latching feature to hold the unit in place until tightened.

*Note: Hold the Ditak front bezel in place when sliding the mounting clip into position.*

6. Alternately tighten each mounting screw to ensure uniform gasket pressure. Visually inspect the gasket for proper seal. The gasket should be compressed approximately 75 to 80% of its original thickness.
7. If the gasket is not adequately compressed and the mounting screws cannot be tightened any further, loosen mounting screws and insure that the clip is latched as close as possible to the panel.
8. Repeat step #6 for tightening the mounting screws.

## TYPICAL APPLICATION

### CONVEYOR BELT SPEED INDICATOR

It is desired to display the rate of a conveyor belt used to carry PC Boards through an Infrared soldering chamber that is variable from 0 to 10 feet per minute. The rate must be adjusted depending on the size of the boards being soldered. The display of the rate indicator must read in hundredths of a foot per minute. The belt is driven by a chain and sprocket. A 26-tooth sprocket is mounted onto the shaft of a variable speed motor. A speed of 1800 RPM will produce a belt speed of 10 ft/min. A magnetic sensor is used to monitor the speed of this sprocket. The Ditak 7 can be used to display the belt speed in this application. The signal input of the sensor is connected to the Ditak 7 Terminal 3 (INP). The sensor common and shield are connected to the Ditak 7 Terminal 1 (GND). The Timebase setting is to be determined by using the formula.

$$\text{TIMEBASE INCREMENT TOTAL (TBIT)} = \frac{\text{DR} \times \text{DDP} \times 15,360}{\text{RPM} \times \text{PPR}}$$

Desired Reading = 10.00  
 MAX RPM Of Shaft = 1800  
 Pulses Per Revolution = 26  
 Display Decimal Point = 100

$$\text{TBIT} = \frac{10.00 \times 100 \times 15,360}{1800 \times 26} = \frac{15,360,000}{46,800} = 328.2$$

TBIT = 328 {round to the nearest whole number}

TBIT = 328

DIP SWB 1 -  $\frac{256}{72}$  - Needed  
 DIP SWA 7 -  $\frac{64}{8}$  - Needed  
 DIP SWA 4 -  $\frac{8}{0}$  - Needed

With these DIP switch settings, the Timebase would be approximately 1.3 sec ( $328 \times 0.004 = 1.312$ ). To reduce the display update time, the "Frequency Doubling" switch can be enabled (set to the "OFF" position). Therefore, only half the Timebase will be necessary ( $164 \times 0.004 = 0.656$  sec.).

$$\text{TBIT} = \frac{328}{2} = 164$$

$$\text{TBIT} = 164$$

DIP SWA 8 -  $\frac{128}{36}$  - Needed  
 DIP SWA 6 -  $\frac{32}{4}$  - Needed  
 DIP SWA 3 -  $\frac{4}{0}$  - Needed  
 DIP SWB 6 - OFF - Frequency Doubling Enabled  
 DIP SWB 7,8 - OFF - 0.00 Decimal Point Position

## ORDERING INFORMATION

Note: Unit shipped with battery installed.

MODEL NO.	DESCRIPTION	PART NUMBER
DT7	Adjustable Timebase Tachometer	DT700000
	Adjustable Timebase Tachometer with Yellow/Green Backlighting	DT700010
	Adjustable Timebase Tachometer with Red Backlighting	DT700020
	Adjustable Timebase Tachometer with V+ Terminal	DT700M00
BNL	3V Lithium Battery	BNL00000
MLPS	Micro Line Sensor/Power Supply	MLPS0000

For more information on Pricing, Enclosures & Panel Mount Kits refer to the RLC Catalog or contact your local RLC distributor.